

HAIMER®
Qualität gewinnt.

ZUBEHÖR ACCESSORIES



www.haimer.com

**FÜR EINE GUTE KOMMUNIKATION
FOR GOOD COMMUNICATION**

Um Ihnen eine schnelle und reibungslose Bearbeitung Ihres Auftrages gewährleisten zu können, bitten wir Sie, diese Nummer in der gesamten Kommunikation mit HAIMER stets anzugeben!

To ensure fast service and smooth processing of purchase orders, please include your HAIMER customer number with all orders and inquiries.

Ihre HAIMER-Kunden-Nummer:
Your HAIMER customer number:

Kunden-Nr.
Customer-No.

Tel./Phone +49-8257-9988-0
Fax +49-8257-1850
E-Mail haimer@haimer.de
Internet www.haimer.com

Haimer GmbH
Weiherstr. 21 · 86568 Igenhausen · Germany
Telefon/Phone +49-8257-9988-0 · Fax +49-8257-1850
haimer@haimer.de · www.haimer.com

Zubehör

Accessories

Artikel/Article	Seite/Page
Schrumpfverlängerungen Shrinking Extensions	4
Reduzierhülsen Reduction Sleeves	8
Cool Jet	9
Cool Flash	10
Spannzangen ER Collets ER	12
Spannzangen für Power Collet Chuck Collets for HAIMER Power Collet Chuck	16
Torque Master Drehmomentschlüssel Torque Master Torque Wrench	18
Werkzeugmontagehilfe Tool Clamp Tool Assembly device Tool Clamp	19
Spannmuttern für Spannzangenfutter Locknuts for collet chucks	20
Spannschlüssel Wrenches	21
HG-Spannzangen und HG-Kegelwischer HG Collets and HG Cone Wiper	22
Anzugsbolzen Pull Studs	23
Sägeblattaufnahmen Sawblade Holders	26
HG Mini Verlängerungen HG Mini Extensions	27
Auswuchtringe Balancing Index Rings	28
Wuchtschraubensatz Set of Balancing Screws	29
Schrumpffutterbürste, Kühlmittelrohr Shrink Fit Brush, Coolant tube	30
Kegelwischer Cone Wiper	31
Einstellschrauben Back up Screws	32
Vorspannfeder für Schrumpffutter Tension Spring for shrink fit chuck	35
Spannschrauben Clamping Screws	36
Messerkopf, Kombi-Zubehör Accessories Face Mill, Combination Shell	37
Schnellwechseleinsätze Typ FH Quick Change Inserts Type FH	38
Umrüstsatz DIN 2080-DIN 69871 Conversion Kit DIN 2080-DIN 69871	39

SCHRUMPFVERLÄNGERUNGEN/SHRINK FIT EXTENSIONS



Die universelle Lösung für Ihre Bearbeitungsfälle

- Absolute Rundlaufgenauigkeit
- Optimale und nahezu unbegrenzte Verlängerungen möglich
- Universell einsetzbar und immer wieder neu verwendbar
- Die wirtschaftlichere Art, Sonderteile zu bearbeiten
- Für HM- und HSS-Schäfte
- Lieferung ohne Kühladapter

The universal solution for your machining issues

- Highest runout accuracy
- Optimum and almost unlimited extensions likely
- Versatile to use and always re-usable
- The most economic way for special machining requirements
- For carbide steel and HSS shanks
- Delivery without cooling adapter

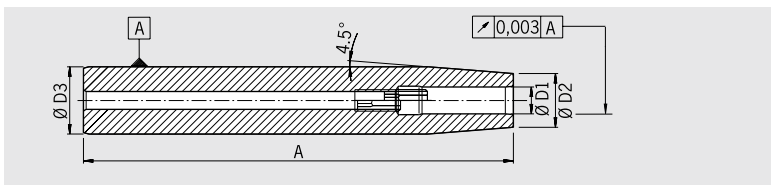

Ausführung:

- Mit Längeneinstellschraube (Verstellweg 10 mm)

Version:

- With set screw (adjustment range 10 mm)

Bestell-Nr. Order No.	Länge A Length A	Außen Ø Outer Ø [mm]	Schafttoleranz Shank tolerance D3 [mm]	Spann Ø Clamping Ø D1 [mm]	Ø D2 [mm]	Kühlung mit Kühlkörper Cooling body	zusätzlich mit Kühladapter Adapter
78.160.06	160	16	h6	6	10	Ø 14-16	80.105.14.1.1
78.200.06	160	20	h6	6	14	Ø 14-16	80.105.14.1.2
78.200.08	160	20	h6	8	14	Ø 14-16	80.105.14.1.2
78.250.08	160	25	h6	8	19	Ø 6-8	—
78.250.10	160	25	h6	10	20	Ø 6-8	—
78.250.12	160	25	h6	12	20	Ø 6-8	—
78.250.14	160	25	h6	14	20	Ø 6-8	—
78.250.16	160	25	h6	16	22	Ø 6-8	—
78.320.10	160	32	h6	10	27	Ø 14-16	—
78.320.12	160	32	h6	12	27	Ø 14-16	—
78.320.14	160	32	h6	14	27	Ø 14-16	—
78.320.16	160	32	h6	16	27	Ø 14-16	—
78.320.18	160	32	h6	18	27	Ø 14-16	—
78.320.20	160	32	h6	20	27	Ø 14-16	—

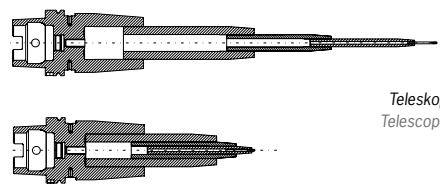
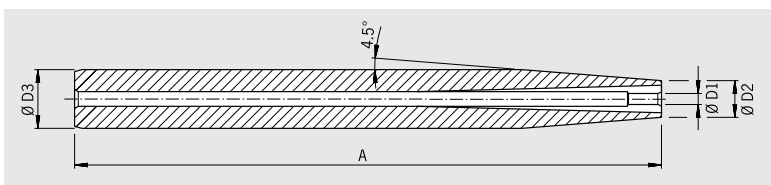

Teleskop
Telescope

Ausführung:

- Ohne Längeneinstellschraube
- Optimale Kühlmittelzuführung von außen durch Schlitze
- Beliebige Längeneinstellung (Teleskop)

Version:

- Without set screw
- With slits along the clamping bore for proper clamping and coolant around the cutting tool
- Variable length setting (telescope)

Bestell-Nr. Order No.	Länge A Length A	Außen Ø Outer Ø [mm]	Schafttoleranz Shank tolerance D3 [mm]	Spann Ø Clamping Ø D1 [mm]	Ø D2 [mm]	Kühlung mit Kühlkörper Cooling body	zusätzlich mit Kühladapter Adapter
78.120.03.2	160	12	h6	3	8	Ø 14-16	80.105.14.1.1
78.120.035.2	160	12	h6	3,5	8	Ø 14-16	80.105.14.1.1
78.120.04.2	160	12	h6	4	8	Ø 14-16	80.105.14.1.1
78.120.045.2	160	12	h6	4,5	8	Ø 14-16	80.105.14.1.1
78.160.03.2	160	16	h6	3	10	Ø 14-16	80.105.14.1.1
78.160.035.2	160	16	h6	3,5	10	Ø 14-16	80.105.14.1.1
78.160.04.2	160	16	h6	4	10	Ø 14-16	80.105.14.1.1
78.160.045.2	160	16	h6	4,5	10	Ø 14-16	80.105.14.1.1
78.160.05.2	160	16	h6	5	10	Ø 14-16	80.105.14.1.1
78.200.05.2	160	20	h6	5	14	Ø 14-16	80.105.14.1.2

SCHRUMPFVERLÄNGERUNGEN/SHRINK FIT EXTENSIONS

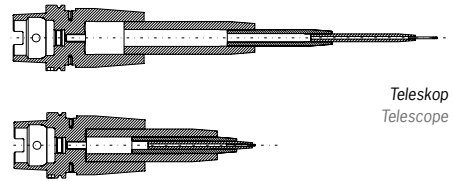
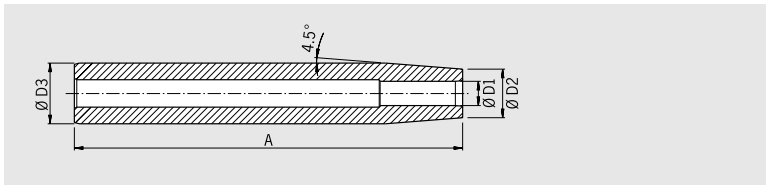

Ausführung:

- Ohne Längeneinstellschraube
- Beliebige Längeneinstellung (Teleskop)

Version:

- Without set screw
- Variable length setting (telescope)

Bestell-Nr. Order No.	Länge A Length A	Außen Ø Outer Ø [mm]	Schafttoleranz Shank tolerance D3 [mm]	Spann Ø Clamping Ø D1 [mm]	Ø D2 [mm]	Kühlung mit Kühlkörper Cooling body	zusätzlich mit Kühladapter Adapter
78.120.03.1	160	12	h4	3	8	Ø 14-16	80.105.14.1.1
78.120.04.1	160	12	h4	4	8	Ø 14-16	80.105.14.1.1
78.160.03.1	160	16	h4	3	10	Ø 14-16	80.105.14.1.1
78.160.04.1	160	16	h4	4	10	Ø 14-16	80.105.14.1.1
78.160.05.1	160	16	h4	5	10	Ø 14-16	80.105.14.1.1
78.160.06.1	160	16	h6	6	10	Ø 14-16	80.105.14.1.1
78.200.05.1	160	20	h4	5	14	Ø 14-16	80.105.14.1.2
78.200.06.1	160	20	h6	6	14	Ø 14-16	80.105.14.1.2
78.200.08.1	160	20	h6	8	14	Ø 14-16	80.105.14.1.2
78.250.08.1	160	25	h6	8	19	Ø 6-8	—
78.250.10.1	160	25	h6	10	20	Ø 6-8	—
78.250.12.1	160	25	h6	12	20	Ø 6-8	—
78.250.14.1	160	25	h6	14	20	Ø 6-8	—
78.250.16.1	160	25	h6	16	22	Ø 6-8	—
78.320.10.1	160	32	h6	10	27	Ø 14-16	—
78.320.12.1	160	32	h6	12	27	Ø 14-16	—
78.320.14.1	160	32	h6	14	27	Ø 14-16	—
78.320.16.1	160	32	h6	16	27	Ø 14-16	—
78.320.18.1	160	32	h6	18	27	Ø 14-16	—
78.320.20.1	160	32	h6	20	27	Ø 14-16	—

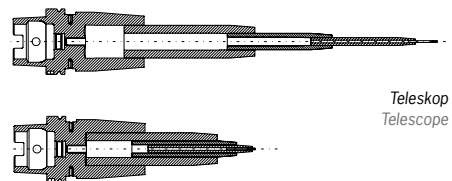
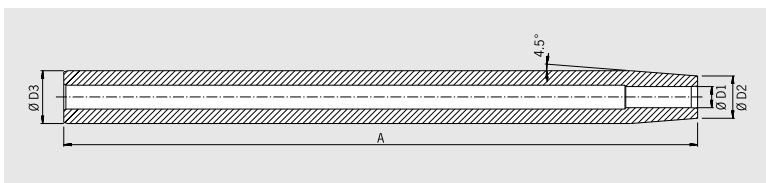

Ausführung: 300 mm lang

- Ohne Längeneinstellschraube
- Beliebige Längeneinstellung (Teleskop)

Version: Extension length 300 mm

- Without set screw
- Variable length setting (telescope)

Bestell-Nr. Order No.	Länge A Length A	Außen Ø Outer Ø [mm]	Schafttoleranz Shank tolerance D3 [mm]	Spann Ø Clamping Ø D1 [mm]	Ø D2 [mm]	Kühlung mit Kühlkörper Cooling body	zusätzlich mit Kühladapter Adapter
78.161.06.1	300	16	h6	6	10	Ø 14-16	80.105.14.1.1
78.201.06.1	300	20	h6	6	14	Ø 14-16	80.105.14.1.2
78.201.08.1	300	20	h6	8	14	Ø 14-16	80.105.14.1.2
78.251.08.1	300	25	h6	8	19	Ø 6-8	—
78.251.10.1	300	25	h6	10	20	Ø 6-8	—
78.251.12.1	300	25	h6	12	20	Ø 6-8	—
78.251.14.1	300	25	h6	14	20	Ø 6-8	—
78.251.16.1	300	25	h6	16	22	Ø 6-8	—
78.321.10.1	300	32	h6	10	27	Ø 14-16	—
78.321.12.1	300	32	h6	12	27	Ø 14-16	—
78.321.14.1	300	32	h6	14	27	Ø 14-16	—
78.321.16.1	300	32	h6	16	27	Ø 14-16	—
78.321.20.1	300	32	h6	20	27	Ø 14-16	—

SCHRUMPFVERLÄNGERUNGEN/SHRINK FIT EXTENSIONS MINI SHRINK VERLÄNGERUNGEN/MINI SHRINK EXTENSIONS

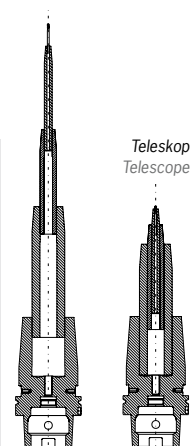
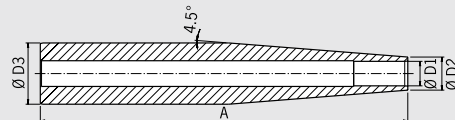

Ausführung: Verlängerung mit Außendurchmesser 50 mm
(Schrumpfen nur mit Power Clamp Profi Plus)

– HSS + HM

Version: Extension with diameter 50 mm
(Shrinking only with Power Clamp Profi Plus)

– HSS + solid carbide

Bestell-Nr. Order No.	Länge A Length A [mm]	Außen Ø Outer Ø D3 [mm]	Schafttoleranz Shank tolerance	Spann Ø Clamping Ø D1 [mm]	Ø D2 [mm]	Kühlung mit Kühlkörper Cooling body
78.501.10.1	300	50	h6	10	24	Ø 10–12
78.501.12.1	300	50	h6	12	24	Ø 14–16
78.501.14.1	300	50	h6	14	27	Ø 14–16
78.501.16.1	300	50	h6	16	27	Ø 14–16
78.501.18.1	300	50	h6	18	27	Ø 14–16
78.501.20.1	300	50	h6	20	33	Ø 25–32
78.501.25.1	300	50	h6	25	44	Ø 25–32
78.501.32.1	300	50	h6	32	44	Ø 25–32

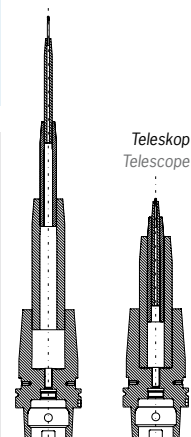
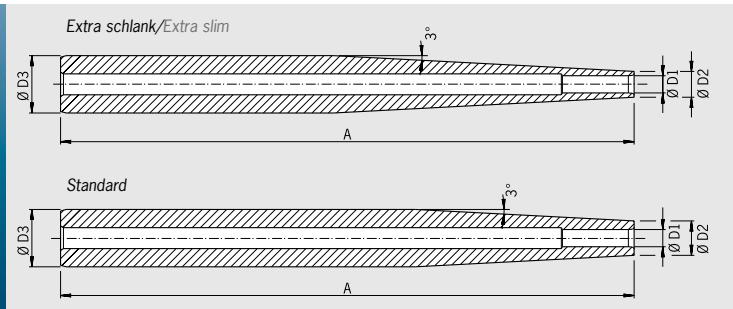

Mini Shrink Verlängerungen (Für alle HM-Werkzeuge mit Schaft-Toleranz h6)

Mini Shrink extensions (For all solid carbide tools with shank tolerance h6)

Standard Bestell-Nr. Order No.	Länge A Length A [mm]	Außen Ø Outer Ø D3 [mm]	Schafttoleranz Shank tolerance	Spann Ø Clamping Ø D1 [mm]	Ø D2 [mm]	Kühlung mit Kühlkörper Cooling body	zusätzlich mit Kühladapter incl. Cooling adapter
77.162.03	160	16	h6	3	9	Ø 6–8	80.105.14.2.04
77.162.04	160	16	h6	4	10	Ø 6–8	80.105.14.2.08
77.162.05	160	16	h6	5	11	Ø 6–8	80.105.14.2.05
77.162.06 ¹⁾	160	16	h6	6	12	Ø 6–8	80.105.14.2.09
77.162.08 ¹⁾	160	16	h6	8	14	Ø 6–8	80.105.14.2.10
77.162.10 ¹⁾	160	16	h6	10	16	Ø 6–8	—
77.202.06	200	20	h6	6	12	Ø 6–8	80.105.14.2.09
77.202.08	200	20	h6	8	14	Ø 6–8	80.105.14.2.10
77.202.10	200	20	h6	10	16	Ø 6–8	80.105.14.2.11
77.202.12	200	20	h6	12	18	Ø 6–8	80.105.14.2.12
Extra schlank/Extra slim							
77.160.03	160	16	h6	3	6	Ø 6–8	80.105.14.2.01
77.160.04	160	16	h6	4	7	Ø 6–8	80.105.14.2.02
77.160.05	160	16	h6	5	8	Ø 6–8	80.105.14.2.03
77.160.06 ¹⁾	160	16	h6	6	9	Ø 6–8	80.105.14.2.04
77.160.08 ¹⁾	160	16	h6	8	11	Ø 6–8	80.105.14.2.05
77.160.10 ¹⁾	160	16	h6	10	13	Ø 6–8	80.105.14.2.06
77.200.06	200	20	h6	6	9	Ø 6–8	80.105.14.2.04
77.200.08	200	20	h6	8	11	Ø 6–8	80.105.14.2.05
77.200.10	200	20	h6	10	13	Ø 6–8	80.105.14.2.06
77.200.12	200	20	h6	12	15	Ø 6–8	80.105.14.2.07

1) Mit Einstellschraube/With set screw

Technische Änderungen vorbehalten
Technical data subject to change without prior notice

HEAVY DUTY SCHRUMPFVERLÄNGERUNGEN HEAVY DUTY SHRINK FIT EXTENSIONS

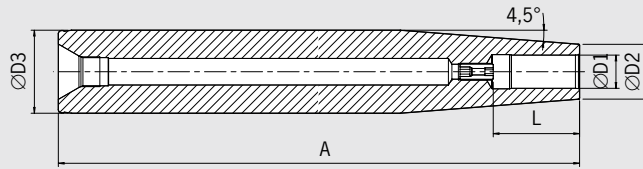

Heavy Duty Schrumpferlängerungen

- HAIMER als Systemanbieter: Die konsequente Ergänzung zu den Heavy Duty Chucks
- Extrem stabil mit 50 mm Außendurchmesser
- Sichere Abstützung des Werkzeuges mit Anschlagsschrauben
- Schwerzerspannung auch in versteckten Winkeln: Länge 400 und 600 mm
- Bei Bedarf können die Verlängerungen auch gekürzt werden
- Auf Wunsch mit Hartmetalleinsatz zur Vibrationsdämpfung

Heavy Duty Shrink Fit Extensions

- HAIMER as full system provider: The consistent addition to the Heavy Duty Chucks
- Extremely stable with 50 mm outer diameter
- Safe support of the tool with setscrews
- Heavy machining also in hidden angles: Length of 400 and 600 mm
- The extensions can be shortened to customer's needs on request
- Solid carbide inserts for vibration dampening on request

Heavy Duty Schrumpferlängerung ohne Hartmetallkern/Heavy Duty Shrink Fit Extensions without solid carbide core

Spann/Clamping	Ø D1 [mm]	16	20	25
	Ø D2 [mm]	27	33	44
	Ø D3 [mm]	50	50	50
	L [mm]	50	52	58
Maß/Length A [mm]	überlang/oversize	400	400	400
Bestell-Nr./Order No.	78.502...	...16	...20	...25
Maß/Length A [mm]	ZG600	600	600	600
Bestell-Nr./Order No.	78.506...	...16	...20	...25

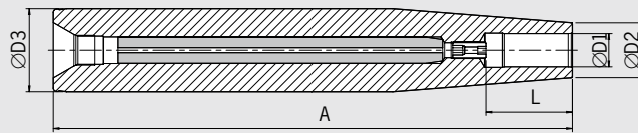

Heavy Duty Schrumpferlängerung mit Hartmetallkern/Heavy Duty Shrink Fit Extensions with solid carbide core

Spann/Clamping	Ø D1 [mm]	16	20	25
	Ø D2 [mm]	27	33	44
	Ø D3 [mm]	50	50	50
	L [mm]	50	52	58
Maß/Length A [mm]	überlang/oversize	400	400	400
Bestell-Nr./Order No.	78.502...	...16.9	...20.9	...25.9
Maß/Length A [mm]	ZG600	600	600	600
Bestell-Nr./Order No.	78.506...	...16.9	...20.9	...25.9

REDUZIERHÜLSEN FÜR MECHANISCHE FUTTER REDUCTION SLEEVES FOR MECHANICAL CHUCKS

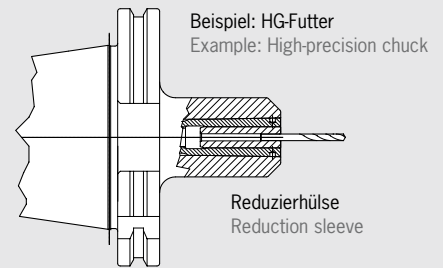
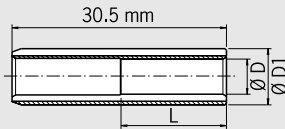

Verwendung:

Zum Spannen von kleinen Schäften in Aufnahmen mit Spanndurchmesser 8 mm.

- Schafttoleranz h6
- Abgedichtet (für Innenkühlung geeignet)

Use:

For clamping small shanks in chucks with $\varnothing 5/16"$ or 8 mm ID's.

- Shank tolerance h6
- Sealed (ready for internal coolant)

[mm]	$\varnothing D$	$\varnothing D1$	L
Bestell-Nr./Order No. 79.110.2.5	2,5	8	7,5
Bestell-Nr./Order No. 79.110.03	3	8	9
Bestell-Nr./Order No. 79.110.3.5	3,5	8	10,5
Bestell-Nr./Order No. 79.110.04	4	8	12
Bestell-Nr./Order No. 79.110.4.5	4,5	8	13,5
Bestell-Nr./Order No. 79.110.05	5	8	15
Bestell-Nr./Order No. 79.110.5.5	5,5	8	16,5

Kann eingesetzt werden in:

- Spannzangenfutter
- Hydrodehnspannfutter
- HG-Futter
- andere hochpräzise mechanische Aufnahmen

For use in all chucks for reduction:

- Collet chucks
- Hydraulic chucks
- HG-chucks
- other high precision mechanical chucks

REDUZIERHÜLSEN FÜR SCHRUMPFUTTER REDUCTION SLEEVES FOR SHRINK FIT CHUCKS

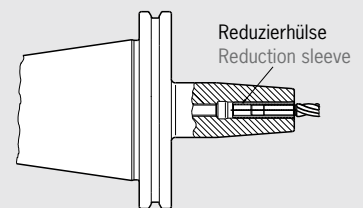
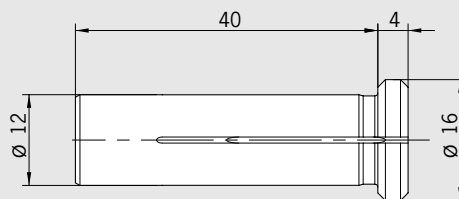

Verwendung:

Zum Spannen von kleinen Schäften in Aufnahmen mit Spanndurchmesser 12 mm.

- Erster Schritt: Reduzierhülse in Werkzeugaufnahme einpressen
Zweiter Schritt: Werkzeugschaft in Reduzierhülse einschrumpfen.

- Schafttoleranz h6

Use:

For clamping small shanks in chucks with 12 mm ID's.

- First step: press reduction sleeve into bore of chuck
Second step: clamp tool shank in reduction sleeve.

- Shank tolerance h6

[mm]	Spann/Clamping $\varnothing D$
Bestell-Nr./Order No. 79.150.03	3
Bestell-Nr./Order No. 79.150.04	4
Bestell-Nr./Order No. 79.150.06	6

**COOL JET – DAMIT SIE DEN SPAN NUR EINMAL SCHNEIDEN!
COOL JET – CUT THE CHIP ONLY ONCE!**

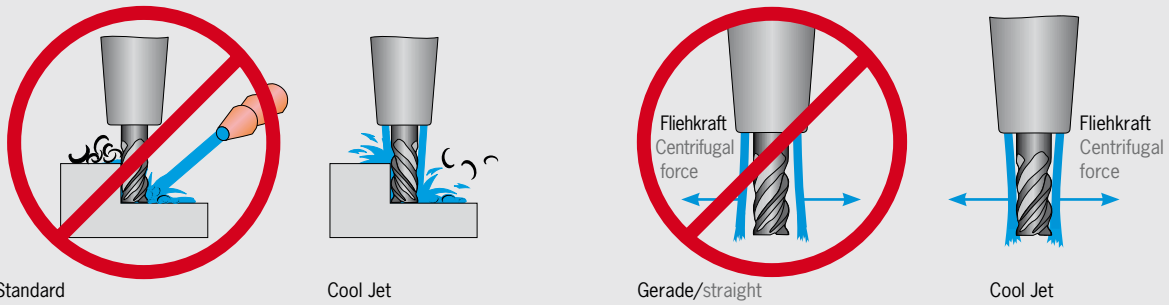

- Optimale Strahlenlenkung bis an die Schneide
- Bis zu 100% höhere Standzeiten
- Erhöhte Prozess-Sicherheit
- Keine Späneknäuel am Werkzeug

- Coolant directly to the cutting edge
- Extended tool life up to 100%
- Higher reliability of cutting process
- No more balls of chips on tool

Verhalten bei hoher Drehzahl

- Bisherige Kühlmittelbohrungen: gerade
- Optimierte Kühlmittelbohrung: schräg

Function at high spindle speed

- Previous coolant bores: straight
- Optimized coolant bores: aimed at center

Cool Jet	Bestell-Nr./Order No.
Cool Jet mit 2 Kühlkanalbohrungen für Schrumpffutter (Ø 6–14 mm), Weldon (Ø 6–20 mm) und HG Spannzangen Cool Jet with 2 Coolant bores for Shrink fit chucks (Ø 6–14 mm), Weldon (Ø 6–20 mm) and HG Collets	91.100.24
Cool Jet mit 3 Kühlkanalbohrungen (Schrumpffutter Ø 16 mm–32 mm) Cool Jet with 3 Coolant bores (Shrink fit chuck Ø 16 mm –32 mm)	91.100.25
Cool Jet mit 4 Kühlkanalbohrungen für Weldon (Ø 25–40 mm) und Whistle Notch (Ø 25–40 mm) Cool Jet with 4 Coolant bores for Weldon (Ø 25–40 mm) and Whistle Notch (Ø 25–40 mm)	91.100.26

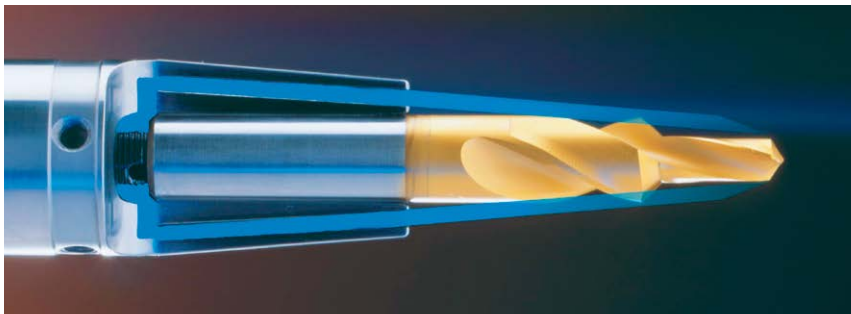

Anwendungsbeispiele

- Einsatz:
- Schrumpffutter
 - HG-Futter
 - Messerkopfaufnahme
 - Weldon

Examples

- For use in:
- Shrink fit chuck
 - HG chuck
 - Face mill holder
 - Weldon



Schrumpffutter
Shrink fit chuck

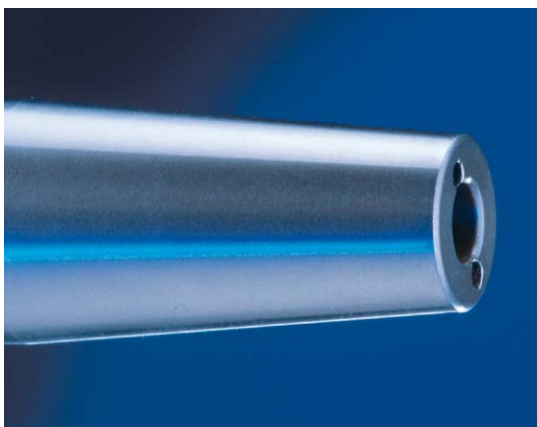

Optimierte Kühlmittelbohrung: schräg
Cool Jet System von HAIMER
Coolant bores aimed at center
Cool Jet by HAIMER



Weldon

Technische Änderungen vorbehalten
Technical data subject to change without prior notice

KÜHLSYSTEM COOL FLASH – KÜHLUNG AUF DIE SPITZE GETRIEBEN
 COOLING SYSTEM COOL FLASH – COOLANT TAKEN TO THE TOP

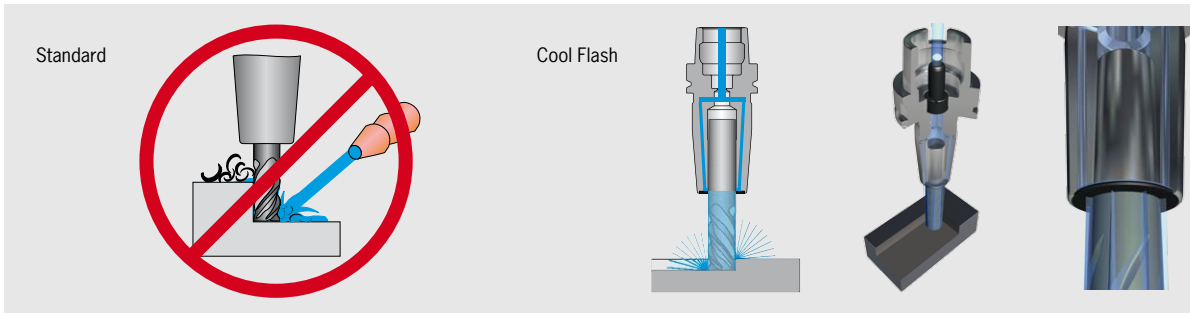

Nach dem Motto „Gutes noch besser machen“ hat HAIMER auf Basis des vorhandenen Cool-Jet das neue Cool Flash-System für Schrumpfaufnahmen entwickelt. Durch mehrere Schlitz tritt der Kühlschmierstoff aus, gleitet am Fräseschaft entlang in die Spannutt und kühlt bis zur Schneide des Werkzeugs!

- Optimale Strahlenkung bis an die Schneide
- Bis zu 100 % höhere Standzeiten
- Keine Späneknäuel am Werkzeug
- Auch bei hohen Drehzahlen
- Optimaler Rundlauf! Keine zusätzliche Unwucht! Keine Störkonturen!
- Für Werkzeuge von Durchm. 6 mm bis 25 mm

True to the slogan “make good things even better” HAIMER has developed the Cool Flash system out of the existing Cool Jet system. The coolant is pressed out by several slots, floats around the shank via the chip flute and cools up to the cutting edge!

- Coolant directly to the cutting edge
- Extended tool life up to 100 %
- Eliminates balls of chips on the cutting tool
- Also for high rpm
- Optimized runout accuracy! No additional unbalance! No disturbing clearance!
- For tools from diam. 6 mm up to 25 mm

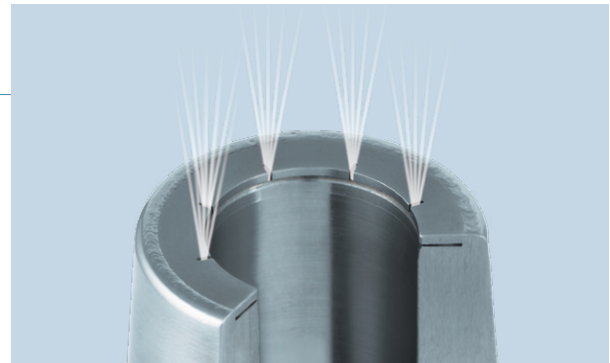

Optimierte Kühlmittelbohrung mit KSS-Austritt durch Schlitz
 Cool Flash System von HAIMER
 Optimized coolant bores with coolant outlet through slots
 Cool Flash by HAIMER

KÜHLSYSTEM COOL FLASH – SIMULATION COOLING SYSTEM COOL FLASH – SIMULATION

Abbildung zeigt: Optimale Kühlmittelzufuhr bis zur Werkzeugspitze in Abhängigkeit von Druck und Drehzahl
Graphic shows: Optimized coolant supply to the top of the cutting tool in dependence of coolant pressure and RPM
Auskräglänge/Protruding length: 28 mm, Werkzeug/Tool Ø 6 mm

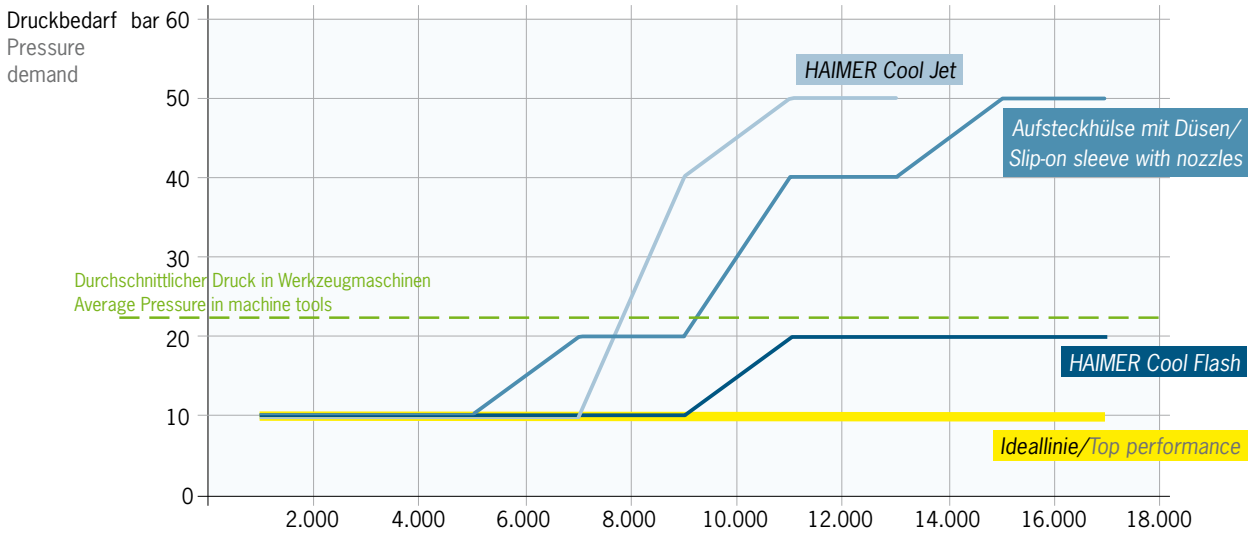

Kühlung bis zur Werkzeugspitze bei 18.000 U/min.
Coolant to the top of the cutting tool @ 18,000 rpm.

Cool Flash vs. interne Kühlung / Cool Flash vs. internal tool cooling		
	Cool Flash	interne Kühlung internal tool cooling
Kühlbereich an der Schneide Cooling range at the cutting edge	✓ 100%	✗ max. 30–40%
Werkzeugstabilität Tool stability	✓ maximal maximum	✗ reduziert reduced
Einsatzbereich Application range	✓ variabel variable	✗ je Fräswerkzeug per cutting tool
Durchmesserbereich Diameter area	✓ ab / from 6 mm	✗ ab / from 12 mm
Anschaffungskosten Acquisition cost	✓ pro Aufnahme per tool holder	✗ pro Fräser per cutting tool

Cool Flash im Vergleich mit Wettbewerbersystemen
Cool Flash compared to competitive systems

Cool Flash		
Cool Flash		Bestell-Nr./Order No. 91.100.40
Cool Flash Upgrade inkl./incl. Cool Jet		Bestell-Nr./Order No. 91.100.41

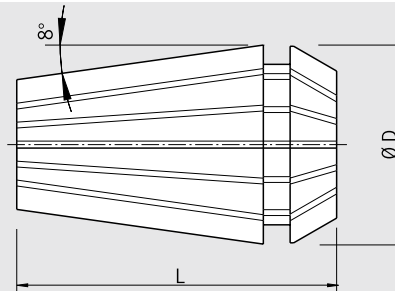

- Polierte Oberfläche garantiert Präzision und Langlebigkeit, insbesondere unter Verwendung von HAIMER ER Spannanzangenfutter
- ISO 15488 (früher DIN 6499)
- Überlegene Haltekräfte
- Passend für ER-Spannzangenfutter aller Hersteller
- Rundlaufgenauigkeit 5 µm

- High polished finish for extra accuracy and long life, especially when clamped in HAIMER ER chucks
- ISO 15488 (formerly DIN 6499)
- Superior clamping strength
- Fits all brands of ER holders
- Run-out accuracy 5 µm

ER 11 Spann/Clamping Ø	[mm]	Ø D	L
Bestell-Nr./Order No. 81.110.1.0	0.50 ... 1.00	11,5	18
81.110.1.5	1.00 ... 1.50	11,5	18
81.110.2.0	1.50 ... 2.00	11,5	18
81.110.2.5	2.00 ... 2.50	11,5	18
81.110.3.0	2.50 ... 3.00	11,5	18
81.110.3.5	3.00 ... 3.50	11,5	18
81.110.4.0	3.50 ... 4.00	11,5	18
81.110.4.5	4.00 ... 4.50	11,5	18
81.110.5.0	4.50 ... 5.00	11,5	18
81.110.5.5	5.00 ... 5.50	11,5	18
81.110.6.0	5.50 ... 6.00	11,5	18
81.110.6.5	6.00 ... 6.50	11,5	18
81.110.7.0	6.50 ... 7.00	11,5	18

ER 16 Spann/Clamping Ø	[mm]	Ø D	L
Bestell-Nr./Order No. 81.160.01	0.50 ... 1.00	17	27
81.160.1.5	1.00 ... 1.50	17	27
81.160.2.0	1.50 ... 2.00	17	27
81.160.2.5	2.00 ... 2.50	17	27
81.160.3.0	2.50 ... 3.00	17	27
81.160.4.0	3.00 ... 4.00	17	27
81.160.5.0	4.00 ... 5.00	17	27
81.160.6.0	5.00 ... 6.00	17	27
81.160.7.0	6.00 ... 7.00	17	27
81.160.8.0	7.00 ... 8.00	17	27
81.160.9.0	8.00 ... 9.00	17	27
81.160.10.0	9.00 ... 10.00	17	27

ER 20 Spann/Clamping Ø	[mm]	Ø D	L
Bestell-Nr./Order No. 81.200.02	1.50 ... 2.00	21	31,5
81.200.03	2.00 ... 3.00	21	31,5
81.200.04	3.00 ... 4.00	21	31,5
81.200.05	4.00 ... 5.00	21	31,5
81.200.06	5.00 ... 6.00	21	31,5
81.200.07	6.00 ... 7.00	21	31,5
81.200.08	7.00 ... 8.00	21	31,5
81.200.09	8.00 ... 9.00	21	31,5
81.200.10	9.00 ... 10.00	21	31,5
81.200.11	10.00 ... 11.00	21	31,5
81.200.12	11.00 ... 12.00	21	31,5
81.200.13	12.00 ... 13.00	21	31,5

ER 25 Spann/Clamping Ø	[mm]	Ø D	L
Bestell-Nr./Order No. 81.250.1.5	1.00 ... 1.50	26	35
81.250.02	1.50 ... 2.00	26	35
81.250.2.5	2.00 ... 2.50	26	35
81.250.03	2.50 ... 3.00	26	35
81.250.04	3.00 ... 4.00	26	35
81.250.05	4.00 ... 5.00	26	35
81.250.06	5.00 ... 6.00	26	35
81.250.07	6.00 ... 7.00	26	35
81.250.08	7.00 ... 8.00	26	35
81.250.09	8.00 ... 9.00	26	35
81.250.10	9.00 ... 10.00	26	35
81.250.11	10.00 ... 11.00	26	35
81.250.12	11.00 ... 12.00	26	35
81.250.13	12.00 ... 13.00	26	35
81.250.14	13.00 ... 14.00	26	35
81.250.15	14.00 ... 15.00	26	35
81.250.16	15.00 ... 16.00	26	35

HOCHPRÄZISIONSSPANNZANGEN ER/HIGH PRECISION COLLETS ER

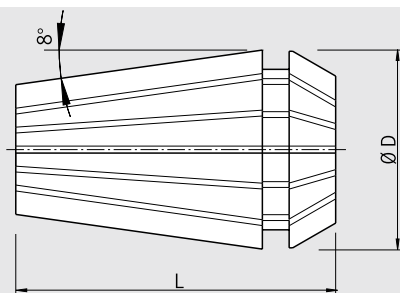

- Polierte Oberfläche garantiert Präzision und Langlebigkeit, insbesondere unter Verwendung von HAIMER ER Spannanzangenfutter
- ISO 15488 (früher DIN 6499)
- Überlegene Haltekräfte
- Passend für ER-Spannzangenfutter aller Hersteller
- Rundlaufgenauigkeit 5 µm

- High polished finish for extra accuracy and long life, especially when clamped in HAIMER ER chucks
- ISO 15488 (formerly DIN 6499)
- Superior clamping strength
- Fits all brands of ER holders
- Run-out accuracy 5 µm

ER 32 Spann/Clamping Ø	[mm]	Ø D	L
Bestell-Nr./Order No. 81.320.02	1.50 ... 2.00	33	40
81.320.2.5	2.00 ... 2.50	33	40
81.320.03	2.50 ... 3.00	33	40
81.320.04	3.00 ... 4.00	33	40
81.320.05	4.00 ... 5.00	33	40
81.320.06	5.00 ... 6.00	33	40
81.320.07	6.00 ... 7.00	33	40
81.320.08	7.00 ... 8.00	33	40
81.320.09	8.00 ... 9.00	33	40
81.320.10	9.00 ... 10.00	33	40
81.320.11	10.00 ... 11.00	33	40
81.320.12	11.00 ... 12.00	33	40
81.320.13	12.00 ... 13.00	33	40
81.320.14	13.00 ... 14.00	33	40
81.320.15	14.00 ... 15.00	33	40
81.320.16	15.00 ... 16.00	33	40
81.320.17	16.00 ... 17.00	33	40
81.320.18	17.00 ... 18.00	33	40
81.320.19	18.00 ... 19.00	33	40
81.320.20	19.00 ... 20.00	33	40

ER 40 Spann/Clamping Ø	[mm]	Ø D	L
Bestell-Nr./Order No. 81.400.03	2.50 ... 3.00	41	46
81.400.04	3.00 ... 4.00	41	46
81.400.05	4.00 ... 5.00	41	46
81.400.06	5.00 ... 6.00	41	46
81.400.07	6.00 ... 7.00	41	46
81.400.08	7.00 ... 8.00	41	46
81.400.09	8.00 ... 9.00	41	46
81.400.10	9.00 ... 10.00	41	46
81.400.11	10.00 ... 11.00	41	46
81.400.12	11.00 ... 12.00	41	46
81.400.13	12.00 ... 13.00	41	46
81.400.14	13.00 ... 14.00	41	46
81.400.15	14.00 ... 15.00	41	46
81.400.16	15.00 ... 16.00	41	46
81.400.17	16.00 ... 17.00	41	46
81.400.18	17.00 ... 18.00	41	46
81.400.19	18.00 ... 19.00	41	46
81.400.20	19.00 ... 20.00	41	46
81.400.21	20.00 ... 21.00	41	46
81.400.22	21.00 ... 22.00	41	46
81.400.23	22.00 ... 23.00	41	46
81.400.24	23.00 ... 24.00	41	46
81.400.25	24.00 ... 25.00	41	46
81.400.26	25.00 ... 26.00	41	46

HOCHPRÄZISIONSSPANNZANGEN ER – ABGEDICHTET HIGH PRECISION COLLETS ER – SEALED

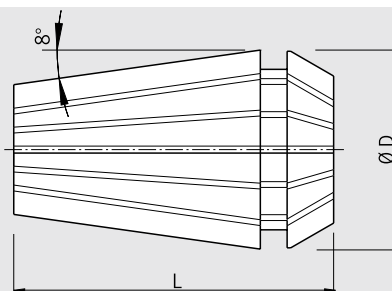

- Polierte Oberfläche garantiert Präzision und Langlebigkeit, insbesondere unter Verwendung von HAIMER ER Spannanzangenfutter
- ISO 15488 (früher DIN 6499)
- Überlegene Haltekräfte
- Passend für ER-Spannzangenfutter aller Hersteller
- Rundlaufgenauigkeit 5 µm
- Mit Abdichtung für Innenkühlung

- High polished finish for extra accuracy and long life, especially when clamped in HAIMER ER chucks
- ISO 15488 (formerly DIN 6499)
- Superior clamping strength
- Fits all brands of ER holders
- Run-out accuracy 5 µm
- Sealed for internal coolant tools

ER 16 Spann/Clamping Ø	[mm]	Ø D	L
Bestell-Nr./Order No. 81.165.03	03	16,70	30
81.165.04	04	16,70	30
81.165.05	05	16,70	30
81.165.06	06	16,70	30
81.165.07	07	16,70	30
81.165.08	08	16,70	30
81.165.09	09	16,70	30
81.165.10	10	16,70	30

ER 20 Spann/Clamping Ø	[mm]	Ø D	L
Bestell-Nr./Order No. 81.205.03	03	20,70	30
81.205.04	04	20,70	30
81.205.05	05	20,70	30
81.205.06	06	20,70	30
81.205.07	07	20,70	30
81.205.08	08	20,70	30
81.205.09	09	20,70	30
81.205.10	10	20,70	30
81.205.11	11	20,70	30
81.205.12	12	20,70	30

ER 25 Spann/Clamping Ø	[mm]	Ø D	L
Bestell-Nr./Order No. 81.255.03	03	25,70	37
81.255.04	04	25,70	37
81.255.05	05	25,70	37
81.255.06	06	25,70	37
81.255.07	07	25,70	37
81.255.08	08	25,70	37
81.255.09	09	25,70	37
81.255.10	10	25,70	37
81.255.11	11	25,70	37
81.255.12	12	25,70	37
81.255.13	13	25,70	37
81.255.14	14	25,70	37
81.255.15	15	25,70	37
81.255.16	16	25,70	37

ER 32 Spann/Clamping Ø	[mm]	Ø D	L
Bestell-Nr./Order No. 81.325.03	03	32,70	45
81.325.04	04	32,70	45
81.325.05	05	32,70	45
81.325.06	06	32,70	45
81.325.07	07	32,70	45
81.325.08	08	32,70	45
81.325.09	09	32,70	45
81.325.10	10	32,70	45
81.325.11	11	32,70	45
81.325.12	12	32,70	45
81.325.13	13	32,70	45
81.325.14	14	32,70	45
81.325.15	15	32,70	45
81.325.16	16	32,70	45
81.325.17	17	32,70	45
81.325.18	18	32,70	45
81.325.19	19	32,70	45
81.325.20	20	32,70	45

ER 40 Spann/Clamping Ø	[mm]	Ø D	L
Bestell-Nr./Order No. 81.405.06	06	40,70	30
81.405.08	08	40,70	30
81.405.10	10	40,70	30
81.405.12	12	40,70	30
81.405.14	14	40,70	30
81.405.16	16	40,70	30
81.405.18	18	40,70	30
81.405.20	20	40,70	30
81.405.22	22	40,70	30
81.405.25	25	40,70	30

HOCHPRÄZISIONSSPANNZANGEN ER – ABGEDICHTET MIT COOL JET

HIGH PRECISION COLLETS ER – SEALED WITH COOL JET

ISO 15488

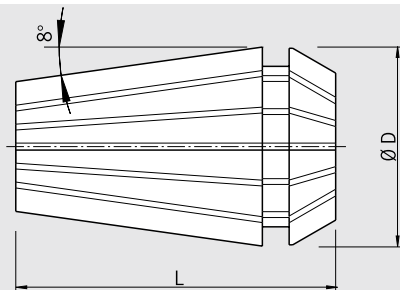

- Polierte Oberfläche garantiert Präzision und Langlebigkeit, insbesondere unter Verwendung von HAIMER ER Spannzangenfutter
- ISO 15488 (früher DIN 6499)
- Überlegene Haltekraft
- Passend für ER-Spannzangenfutter aller Hersteller
- Rundlaufgenauigkeit 5 µm
- Mit Cool Jet Bohrungen für optimale Kühlmittelzufuhr

- High polished finish for extra accuracy and long life, especially when clamped in HAIMER ER chucks
- ISO 15488 (formerly DIN 6499)
- Superior clamping strength
- Fits all brands of ER holders
- Run-out accuracy 5 µm
- With Cool Jet bores for optimal coolant supply

ER 25 Spann/Clamping Ø	[mm]	Ø D	L
Bestell-Nr./Order No. 81.252.04	04	26	37
81.252.06	06	26	37
81.252.08	08	26	37
81.252.10	10	26	37
81.252.12	12	26	37
81.252.14	14	26	37

ER 32 Spann/Clamping Ø	[mm]	Ø D	L
Bestell-Nr./Order No. 81.322.04	04	33	45
81.322.06	06	33	45
81.322.08	08	33	45
81.322.10	10	33	45
81.322.12	12	33	45
81.322.14	14	33	45
81.322.16	16	33	45
81.322.18	18	33	45

SPANNZANGE FÜR HAIMER POWER COLLET CHUCK
COLLET FOR HAIMER POWER COLLET CHUCK

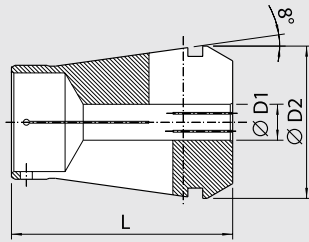

Spannzange Power Collet/Power Collet

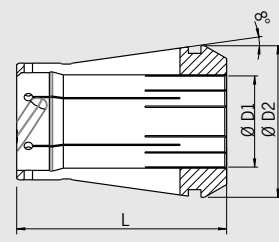

Spannzange Power Collet mit Safe-Lock™
Power Collet with Safe-Lock™

- Hohe Rundlaufgenauigkeit: 0,003 mm bei 3 × D
- Überlegene Haltekräfte
- Passend für HAIMER Power Collet Chucks
- Für Werkzeuge mit zylindrischem Schaft mit Schafttoleranz h10
- Optional: Cool Jet Bohrungen ab Ø 6 mm bei ER 25 und ER 32

- High runout accuracy: 0.003 mm at 3 × D
- Superior clamping strength
- Fits HAIMER Power Collet Chucks
- For cylindrical shanks with tolerance h10
- Optional: Cool Jet bores from Ø 6 mm at ER25 and ER 32

ER 16 Spann/Clamping Ø [mm]	D1	D2	L
Bestell-Nr./Order No. 81.163.02	2	16,45	30
81.163.03	3	16,45	30
81.163.04	4	16,45	30
81.163.05	5	16,45	30
81.163.06	6 ¹⁾	16,45	30
81.163.08	8 ¹⁾	16,45	30
81.163.10	10 ¹⁾	16,45	30

ER 25 Spann/Clamping Ø [mm]	D1	D2	L
Bestell-Nr./Order No. 81.253.02	2	25,45	37
81.253.03	3	25,45	37
81.253.04	4	25,45	37
81.253.05	5	25,45	37
81.253.06	6 ¹⁾	25,45	37
81.253.08	8 ¹⁾	25,45	37
81.253.10	10 ¹⁾	25,45	37
81.253.12	12 ¹⁾	25,45	37
81.253.14	14 ¹⁾	25,45	37
81.253.16	16 ¹⁾	25,45	37

ER 32 Spann/Clamping Ø [mm]	D1	D2	L
Bestell-Nr./Order No. 81.323.02	2	32,48	45
81.323.03	3	32,48	45
81.323.04	4	32,48	45
81.323.05	5	32,48	45
81.323.06	6 ¹⁾	32,48	45
81.323.08	8 ¹⁾	32,48	45
81.323.10	10 ¹⁾	32,48	45
81.323.12	12 ¹⁾	32,48	45
81.323.14	14 ¹⁾	32,48	45
81.323.16	16 ¹⁾	32,48	45
81.323.18	18 ¹⁾	32,48	45
81.323.20	20 ¹⁾	32,48	45

POWER COLLET SPANNZANGE MIT SAFE-LOCK®
POWER COLLET WITH SAFE-LOCK®

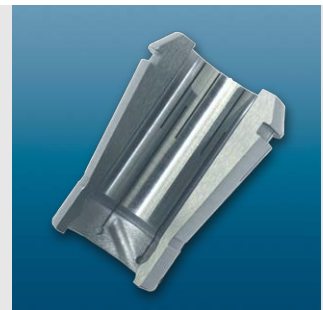

ER 25 (6,0-16,0)	Spann/Clamping Ø D1 [mm]	06	08	10	12	14	16		
Bestell-Nr./Order No. 81.253...		...06.7	...08.7	...10.7	...12.7	...14.7	...16.7		
ER 32 (6,0-20,0)	Spann/Clamping Ø D1 [mm]	06	08	10	12	14	16	18	20
Bestell-Nr./Order No. 81.323...		...06.7	...08.7	...10.7	...12.7	...14.7	...16.7	...18.7	...20.7

Zubehör/Accessories

Cool Jet Bohrungen für Power Collet Spannzangen/Cool Jet bores for Power Collets

Bestell-Nr./Order No. **91.100.27**



1) Selbstdichtend für Innenkühlung/Sealed for internal coolant

Technische Änderungen vorbehalten
Technical data subject to change without prior notice

Mit optimaler Spannung für mehr Präzision:
Power Collet Drehmomentschlüssel und
Werkzeugmontagehilfe Tool Clamp.

With optimal clamping for more precision:
Torque wrench for Power Collet Chucks
and tool assembly device Tool Clamp.



TORQUE MASTER DREHMOMENTSCHLÜSSEL FÜR HAIMER POWER COLLET CHUCK UND STANDARD ER FUTTER TORQUE MASTER TORQUE WRENCH FOR HAIMER POWER COLLET CHUCK AND STANDARD ER CHUCKS

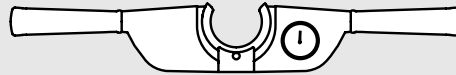

Zweiarmiger Drehmomentschlüssel für Power Collet Chucks:

- Für höchste Rundlaufgenauigkeit, kein einseitiges Spannen
- Optimale Kraftübertragung durch gleichmäßige Kräfteinleitung
- Drehmomentschlüssel für höchste Spann- und Wiederholgenauigkeit mit Messuhr
- Maximales Drehmoment für höchste Haltekräfte
- Keine Überlastung kleiner Spanndurchmesser
- Auswechselbare Einsätze, auch für Standard ER-Muttern geeignet

Two-armed torque wrench for Power Collet Chucks:

- For highest runout accuracy, no one-sided clamping
- Optimal power transmission by constant force application
- Torque wrench for highest clamping accuracy and repeatability with dial gauge
- Maximum torque for highest clamping force
- No overloading of smaller clamping diameters
- Changeable inserts, useable also for standard ER-Collets

Torque Master Drehmomentschlüssel/Torque wrench	Größe/Size
Bestell-Nr./Order No.	
84.600.00	ER 16/ER 25/ER 32

POWER COLLET EINSÄTZE FÜR DREHMOMENTSCHLÜSSEL POWER COLLET INSERTS FOR TORQUE MASTER



Power Collet Einsätze/Power Collet torque wrench inserts	Größe/Size
Bestell-Nr./Order No.	
84.610.16	ER 16
84.610.25	ER 25
84.610.32	ER 32

Zubehör/Accessories

Einsätze für Standard ER Futter/Inserts for standard ER chucks

Bestell-Nr./Order No. 84.620...	...16	...20	...25	...32
---------------------------------	-------	-------	-------	-------

WERKZEUGMONTAGEHILFE TOOL CLAMP MIT VERSCHIEDENEN ADAPTERN TOOL ASSEMBLY DEVICE TOOL CLAMP WITH VARIOUS ADAPTERS

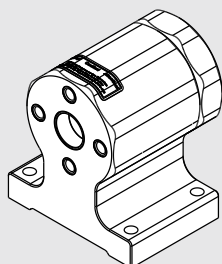

Das neue Werkzeug-Montagegerät:

- Sichere Werkzeugmontage ohne Kraftaufwand
- Schnellwechsel für verschiedene Werkzeugsysteme – ohne zusätzliches Werkzeug
- Unfallsicherer und müheloser Wechsel von Schneidwerkzeugen
- Federnder Rastbolzen
- Kraftschlüssiger Sperrbolzen
- Besser gespannte Werkzeuge dank optimaler Ergonomie
- Austauschbare Messing-Einsätze schonen die Konusoberfläche
- Platzbedarf 140 x 100 mm

The new tool assembly device:

- Secure tool assembling
- Minimum locking force needed
- Quick-change function for different taper interfaces – without additional tooling
- Accident-free assembling of cutting tools
- Spring-loaded locking pin
- Mechanical security pin
- Better tool clamping thanks to optimum ergonomics
- Replaceable brass tool pots protect the taper surface
- Required space 140 x 100 mm



Tool Clamp



Werkzeugaufnahme SK
Tool holder SK

Tool Clamp – ohne Werkzeugaufnahmen, 4 x 90° indexierbar Tool Clamp – without tool holder, 4 x 90° indexable

Bestell-Nr./Order No.

84.700.00

Werkzeugaufnahme SK/Tool holder SK (DIN/MAS-BT/CAT)

Bestell-Nr./Order No.

Typ/Type

84.701.30

SK/ISO 30

84.701.40

SK/ISO 40

84.701.50

SK/ISO 50

Werkzeugaufnahme HSK-A/Tool holder HSK-A (DIN 69893/1)

Bestell-Nr./Order No.

Typ/Type

84.702.40

HSK-A40

84.702.50

HSK-A50

84.702.63

HSK-A63

84.702.80

HSK-A80

84.702.10

HSK-A100

Werkzeugaufnahme HSK-C/HSK-E/Tool holder HSK-C/HSK-E (DIN 69893/1)

Bestell-Nr./Order No.

Typ/Type

84.703.32

HSK-C/E32

84.703.40

HSK-C/E40

84.703.50

HSK-C/E50

84.703.63

HSK-C/E63

84.703.80

HSK-C/E80

Werkzeugaufnahme HSK-F/Tool holder HSK-F

Bestell-Nr./Order No.

Typ/Type

84.704.63

HSK-F63

84.704.80.M

HSK-F80 MAKINO

Werkzeugaufnahme Capto/Tool holder Capto

Bestell-Nr./Order No.

Typ/Type

84.705.40

Capto C4

84.705.50

Capto C5

84.705.60

Capto C6

Werkzeugaufnahme KM4X100/Tool holder KM4X100

Bestell-Nr./Order No.

Typ/Type

84.706.4X.100

KM4X

Technische Änderungen vorbehalten
Technical data subject to change without prior notice

SPANNMUTTERN FÜR SPANNZANGENFUTTER
 LOCKNUTS FOR COLLET CHUCKS

ER 11–20
 für Gabelschlüssel
 for fork wrench

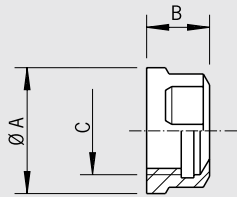

ER 25–40
 für ER Spannschlüssel
 for ER clamping wrench

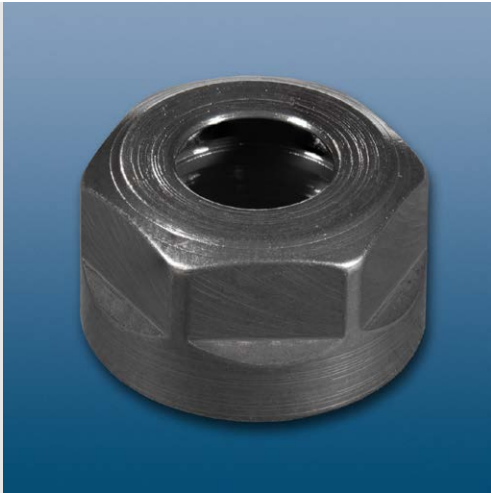
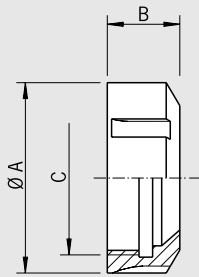

Spannmuttern ER:

- Höchste Rundlaufgenauigkeit
- Kein Verschleiß und hohe Spannkraft durch spezielle Gleitbeschichtung
- Geringe Vibrationen durch Vorwuchtung
- Ausführung HS feingewuchtet

Locknuts ER:

- Highest runout accuracy
- No wear and high clamping force due to special slide coating
- Small vibrations due to pre-balancing
- Version HS fine-balanced

ER	ER 11	ER 16	ER 20		
Bestell-Nr./Order No. 83.912...	...11	...16	...20		
HS Version					
Bestell-Nr./Order No. 83.912...		...16.HS	...20.HS		
Ø A	19	28	34		
B	11,3	17	19		
C	M 14 x 0,75	M 22 x 1,5	M 25 x 1,5		
ER		ER 25	ER 32	ER 40	
Bestell-Nr./Order No. 83.912...		...25	...32	...40	
HS Version					
Bestell-Nr./Order No. 83.912...		...25.HS	...32.HS	...40.HS	
Ø A		42	50	63	
B		20	22,3	25,3	
C		M 32 x 1,5	M 40 x 1,5	M 50 x 1,5	

SPANNSCHLÜSSEL/WRENCHES



Power Collet Spannschlüssel für ER 16, ER 25 und ER 32/Power Collet clamping wrench for ER 16, ER 25 and ER 32

ER	ER 16	ER 25	ER 32
Bestell-Nr./Order No. 84.650...	...16	...25	...32



Gabelschlüssel für Spannmutter ER 11, ER 16 und ER 20/Wrench for locknuts ER 11, ER 16 and ER 20

ER	ER 11	ER 16	ER 20
Schlüsselweite SW/Wrench size	17	25	30
Bestell-Nr./Order No. 84.200...	...11	...16	...20

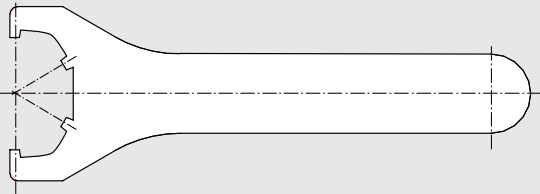

Spannschlüssel für Spannmutter ER 25-40/Wrench for locknuts ER 25-40

ER	ER 25	ER 32	ER 40
Bestell-Nr./Order No. 84.200...	...25	...32	...40



Nasenschlüssel DIN 6368 für Kombiaufsteckfräserdorne und Messerkopfpaufnahmen Ø 16-60
Wrench for tightening bolts for face mill arbors and combination shell end mill adapters Ø 16-60

Ø	16	22	27	32	40	50	60
Bestell-Nr./Order No. 84.400...	...16	...22	...27	...32	...40	...50	...60

HG-SPANNZANGEN UND HG-KEGELWISCHER HG COLLETS AND HG CONE WIPER

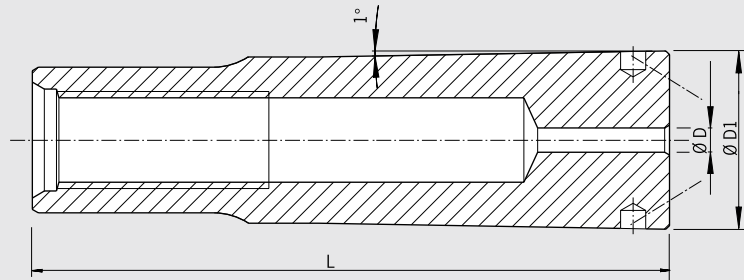

HG-Spannzangen

Zum hochgenauen Spannen von Werkzeugen mit zylindrischem Schaft in HG-Futtern.

– Für Werkzeuge mit Schafttoleranz h6

HG Collets

For clamping tools with cylindrical shank with utmost precision in HG chucks.

– For tools with Shank tolerance h6

HG 01	Ø D [mm]	2	2,5	3	4	4,5	5	5,5	5,6 ¹⁾	6	6,3	7	7,1 ¹⁾	8	9
	Ø D1[mm]	14,7	14,7	14,7	14,7	14,7	14,7	14,7	14,7	14,7	14,7	14,7	14,7	14,7	14,7
	L [mm]	52,5	52,5	52,5	52,5	52,5	52,5	52,5	52,5	52,5	52,5	52,5	52,5	52,5	52,5
Bestell-Nr./Order No.	82.510...	...02	...02.5	...03	...04	...04.5	...05	...05.5	...05.6	...06	...06.3	...07	...07.1	...08	...09
HG 02	Ø D [mm]	10	11	12	12,5	14									
	Ø D1[mm]	17,87	17,87	17,87	17,87	17,87									
	L [mm]	64,2	64,2	64,2	64,2	64,2									
Bestell-Nr./Order No.	82.520...	...10	...11	...12	...12.5	...14									
HG 03	Ø D [mm]	16	18	20											
	Ø D1[mm]	26,147	26,147	26,147											
	L [mm]	69,7	69,7	69,7											
Bestell-Nr./Order No.	82.530...	...16	...18	...20											

Zubehör/Accessories

Ausziehhaken/Pull-out hook

HG

Bestell-Nr./Order No. **82.570.00**



Schmierpaste/Lubricating paste

Bestell-Nr./Order No. **82.585.00**

Cool Jet Bohrungen/Cool Jet bores

Bestell-Nr./Order No. **91.100.24**



Siehe Seite 9/See page 9

Kegelwischer

Zum Reinigen des Innenkonus des HG-Futters.

Cone wiper

For cleaning tool holder I.D. of HG chuck.

Kegelwischer/Cone wiper	HG 01	HG 02	HG 03
Bestell-Nr./Order No. 82.590...	...01	...02	03

ANZUGSBOLZEN/PULL STUDS

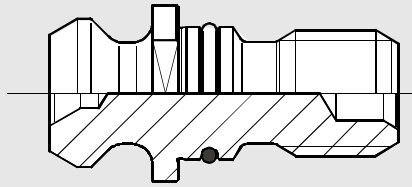
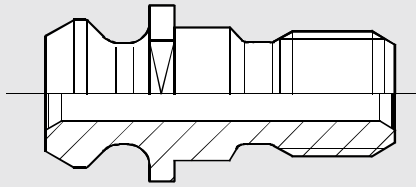

Anzugsbolzen sind ein wichtiges Bindeglied zwischen Maschine und Werkzeug. Die Anforderungen an Genauigkeit, Festigkeit und Zuverlässigkeit sind hoch. Minderwertige Anzugsbolzen beeinträchtigen nicht nur die Leistungsfähigkeit der Maschine, sondern sie stellen sogar ein Sicherheitsrisiko dar. Brechende Anzugsbolzen können nicht nur Kosten an Maschine und Werkstück verursachen, sondern auch schwere Personenschäden.

Pull studs are an important link between machine and tool. The requirements concerning accuracy, rigidity and reliability are very high. Pull studs of minor quality not only decrease the performance of the machine, they are even a safety risk. A breaking pull stud might cause severe damage on machine and workpiece and even injuries on persons.

- Gefertigt aus hochfestem Spezialstahl
- Aufwändige Wärmebehandlung in mehreren Schritten
- Gezieltes Anlassen der am höchsten belasteten Bereiche
- Hohe Schlagzähigkeit
- Alle Funktionsflächen nach dem Härten fein bearbeitet
- Höchste Sicherheit und Zuverlässigkeit

- Made of special steel with high rigidity
- Costly heat treatment in several steps
- Spots with highest stress tempered specifically
- High impact strength
- All functional surfaces fine finished after hardening
- Highest security and reliability

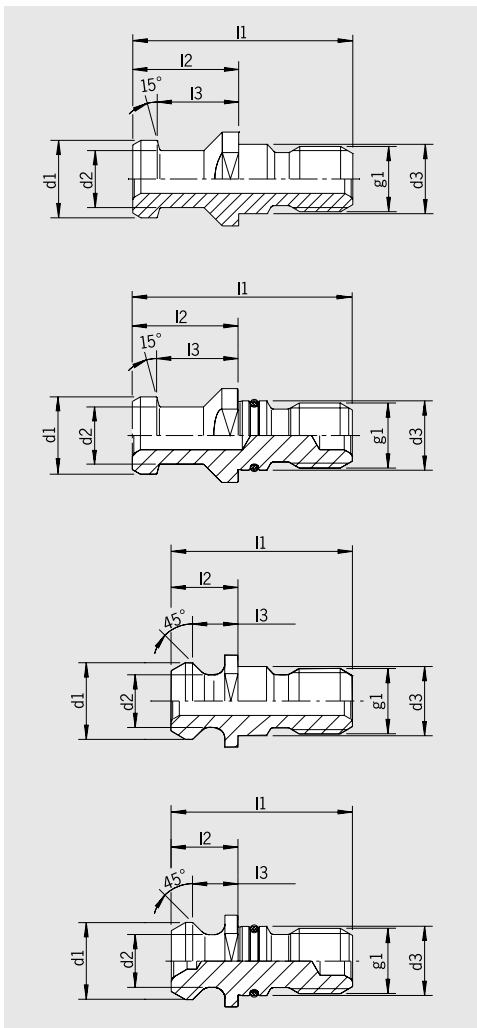

DIN 69872 Form A mit Durchgangsbohrung/with drill through							
	d1	d2	d3	l1	l2	l3	g1
SK 40							
Bestell-Nr./Order No. 88.200.40	19	14	17	54	26	20	M16
SK 50							
Bestell-Nr./Order No. 88.200.50	28	21	25	74	34	25	M24

DIN 69872 Form B abgedichtet/sealed							
	d1	d2	d3	l1	l2	l3	g1
SK 40							
Bestell-Nr./Order No. 88.202.40	19	14	17	54	26	20	M16
SK 50							
Bestell-Nr./Order No. 88.202.50	28	21	25	74	34	25	M24

ISO 7388 B mit Durchgangsbohrung/with drill through							
	d1	d2	d3	l1	l2	l3	g1
SK 40							
Bestell-Nr./Order No. 88.400.40	18,95	12,95	17	44,5	16,4	11,15	M16
SK 50							
Bestell-Nr./Order No. 88.400.50	29,1	19,6	25	65,5	25,55	17,95	M24

ISO 7388 B abgedichtet/sealed							
	d1	d2	d3	l1	l2	l3	g1
SK 40							
Bestell-Nr./Order No. 88.402.40	18,95	12,95	17	44,5	16,4	11,15	M16
SK 50							
Bestell-Nr./Order No. 88.402.50	29,1	19,6	25	65,5	25,55	17,95	M24

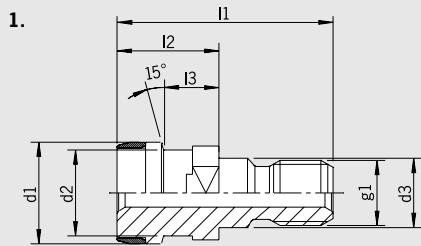

1. Ott-Ringnut mit Durchgangsbohrung/Ott-groove with drill through

	d1	d2	d3	l1	l2	l3	g1
SK40							
Bestell-Nr./Order No. 88.300.40	25	21,1	17	53	25	13,6	M16
SK50							
Bestell-Nr./Order No. 88.300.50	39,3	32	25	65	25	13,35	M24

SK40 mit Messingschutzring/SK40 with protective ring of brass

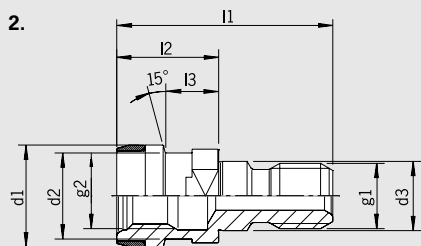

2. Ott-Ringnut mit Innengewinde/Ott-groove with inner thread

	d1	d2	d3	l1	l2	l3	g1	g2
SK40								
Bestell-Nr./Order No. 88.303.40	25	21,1	17	53	25	13,6	M16	M16
SK50								
Bestell-Nr./Order No. 88.303.50	39,3	32	25	65	25	13,35	M24	M24

SK40 mit Messingschutzring/SK40 with protective ring of brass

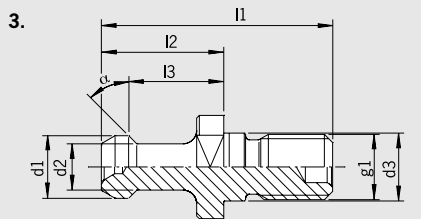

3. MAS 403 30°/45°

	d1	d2	d3	l1	l2	l3	g1	α
BT30 30°								
Bestell-Nr./Order No. 88.604.30	11	7	12,5	43	23	18	M12	30°
BT30 45°								
Bestell-Nr./Order No. 88.601.30	11	7	12,5	43	23	18	M12	45°
BT40 45°								
Bestell-Nr./Order No. 88.601.40	15	10	17	60	35	28	M16	45°
BT40 45° verkürzt/shortened								
Bestell-Nr./Order No. 88.601.40.1	15	10	17	57,15	32,15	25,15	M16	45°
BT40 45° mit Bohrung Ø 3,5/with bore Ø 3,5								
Bestell-Nr./Order No. 88.603.40	15	10	17	60	35	28	M16	45°
BT40 30°								
Bestell-Nr./Order No. 88.604.40	15	10	17	60	35	28	M16	30°
BT50 45°								
Bestell-Nr./Order No. 88.601.50	23	17	25	85	45	35	M24	45°
BT50 30°								
Bestell-Nr./Order No. 88.604.50	23	17	25	85	45	35	M24	30°

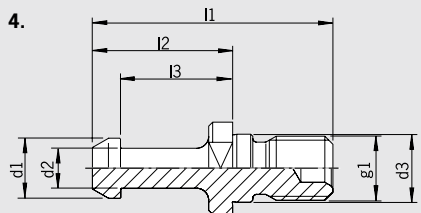

4. MORI – SEIKI MAS 90°

	d1	d2	d3	l1	l2	l3	g1
BT40							
Bestell-Nr./Order No. 88.101.40	15	10	17	60	35	28	M16
BT50							
Bestell-Nr./Order No. 88.101.50	23	17	25	85	45	35	M24

ANZUGSBOLZEN/PULL STUDS

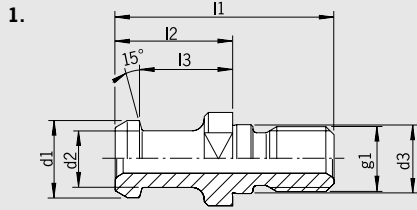

1. JIS B 6339 mit Durchgangsbohrung/with drill through							
	d1	d2	d3	l1	l2	l3	g1
BT40							
Bestell-Nr./Order No. 88.700.40	19	14	17	54	29	23	M16
BT40 mit Passungssitz/with pilot							
Bestell-Nr./Order No. 88.800.40	19	14	17	54	26	20	M16
BT50							
Bestell-Nr./Order No. 88.700.50	28	21	25	74	34	25	M24
BT50 mit Passungssitz/with pilot							
Bestell-Nr./Order No. 88.800.50	28	21	25	74	34	25	M24

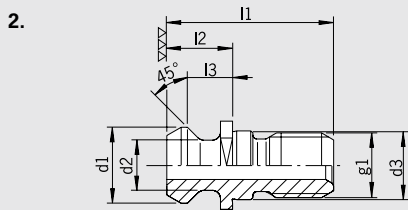

2. ANSI – CAT 40 (MAZAK) mit Durchgangsbohrung/with drill through							
	d1	d2	d3	l1	l2	l3	g1
CAT40							
Bestell-Nr./Order No. 88.500.40	18,80	12,45	17	41,26	16,26	11,18	M16
Dichtfläche an Stirnseite/sealing on face side							
CAT40 mit Passungssitz/with pilot							
Bestell-Nr./Order No. 88.500.40.1	18,80	12,45	17	41,26	16,26	11,18	M16

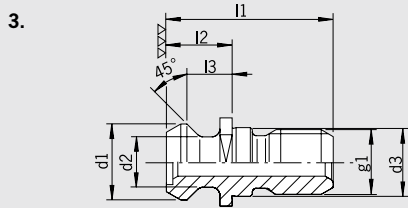

3. ANSI – CAT 50 (MAZAK) mit Durchgangsbohrung/with drill through							
	d1	d2	d3	l1	l2	l3	g1
CAT50							
Bestell-Nr./Order No. 88.500.50	28,96	20,83	25	65,4	25,4	17,78	M24
mit O-Ring/with o-ring							

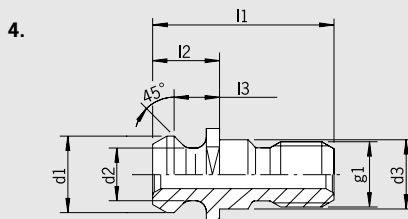

4. ANSI – CAT 40 (MAZAK)							
	d1	d2	d3	l1	l2	l3	g1
CAT40 verlängert/extended							
Bestell-Nr./Order No. 88.900.40.1	18,80	12,45	17	44,11	19,11	14,03	M16
Dichtfläche an Stirnseite/sealing on face side							

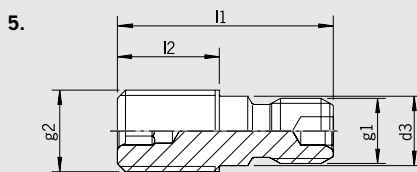

5. Anzugsbolzen mit Sägewinde S 20x2/with saw thread S 20x2								
	d1	d2	d3	l1	l2	l3	g1	g2
SK40								
Bestell-Nr./Order No. 88.600.40	—	—	17	53	25	—	M16	S20x2

SÄGEBLATTAFNAHME/SAWBLADE HOLDER

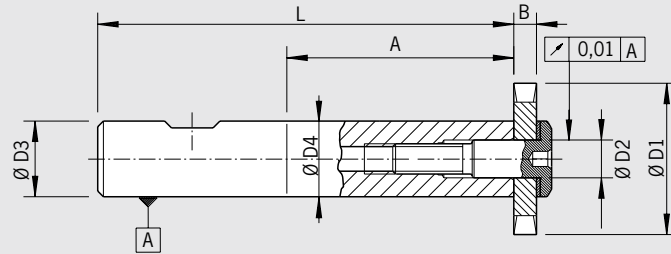

Verwendung:

Zur Aufnahme von Sägeblättern über Weldon-Aufnahmen.

Schaftausführung nach

DIN 1835-B

hochvergütet, Außen- und Innen-Ø geschliffen

- Lieferumfang: komplett mit Spannschraube und Zwischenring
- Kühlung mit Cool Jet gegen Aufpreis

Use:

For holding sawblades on Weldon tool holders.

Design of shank according to

DIN 1835-B

well quenched and tempered, internally and externally ground

- Included in delivery: completely with tightening bolt and intermediate disk
- Cooling with Cool Jet against extra charge

Sägeblatt/Sawblade Ø D1 [mm]	20	25	32	40	50	63
Ø D2 [mm]	5	8	8	10	13	16
Ø D3 [mm]	20	20	20	20	25	25
Ø D4 [mm]	10	13	16	20	25	25
L [mm]	90	100	105	110	136	136
B 0,2 mm – 6 mm						

Maß/Length A [mm]	40	50	55	60	80	80
Bestell-Nr./Order No. 79.200...	...20	...25	...32	...40	...50	...63

Sägeblattaufnahmensatz

bestehend aus allen sechs Größen inkl. Werkzeugträger/Tool bar incl. 6 pcs. sawblade adapter

Bestell-Nr./Order No. 79.200.00

Zubehör/Accessories

Spannschraube/Tightening bolt

Größe/Size D1

Bestell-Nr./Order No. 79.250...



20	25	32	40	50	63
...20	...25	...32	...40	...50	...63

Scheibe/Disk

Größe/Size D1

Bestell-Nr./Order No. 79.260...



20	25	32	40	50	63
...20	...25	...32	...40	...50	...63

Cool Jet Bohrungen/Cool Jet bores

Bestell-Nr./Order No. 91.100.24



Siehe Seite 9/See page 9

HG MINI VERLÄNGERUNGEN HG MINI EXTENSIONS

HG Mini 01
zylindrisch/cylindrical



HG Mini 01
konisch/conical

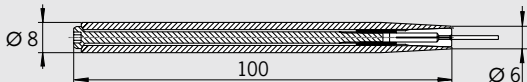

HG Mini 02
zylindrisch/cylindrical



	HG Mini 01 zylindrisch/cylindrical	HG Mini 01 konisch/conical	HG Mini 02 zylindrisch/cylindrical
Größe/Size	A=100 mm	A=100 mm	A=130 mm
Außen-Ø/Outer diam.	6 mm zylindrisch/cylindrical	6-8 mm konisch/conical	10 mm zylindrisch/cylindrical
Spannbereich/Clamping range Ø	1-2,5 mm	1-2,5 mm	2,5-4,5 mm
Bestell-Nr./Order No.	82.611.01	82.621.01	82.610.02

Spannzangen für HG Mini 01/Collets for HG Mini 01

Spann/Clamping	Ø D [mm]	1	1,5	2	2,5
Bestell-Nr./Order No. 82.650...		...010	...015	...020	...025

Spannzangen für HG Mini 02/Collets for HG Mini 02

Spann/Clamping	Ø D [mm]	2	2,5	3	3,5	4	4,5
Bestell-Nr./Order No. 82.660...		...020	...025	...030	...035	...040	...045



HG Mini mit Drehmomentschlüssel und Montagehilfe
HG Mini with torque wrench and assembly device



Montagehilfe für HG Mini
Assembly device for HG Mini

Zubehör/Accessories

Drehmomentschlüssel für HG Mini (voreingestellt)/Torque wrench for HG Mini (pre-adjusted)

Größe/Size	01	02
Bestell-Nr./Order No.	82.576.00	82.577.00

Montagehilfe für HG Mini/Assembly device for HG Mini

Bestell-Nr./Order No.	82.578.00
------------------------------	------------------

AUSWUCHTRINGE/BALANCING INDEX RINGS

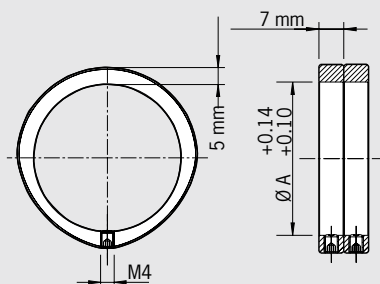

Zum Feinwuchten von allen Werkzeugaufnahmen mit zylindrischem Außendurchmesser ($\varnothing A$).

Die Auswuchtringe tragen selbst eine genau definierte Unwucht. Sie werden so gedreht, dass die Unwucht der Werkzeugaufnahme genau ausgeglichen wird. Es werden immer 2 Ringe pro Auswuchtebene benötigt.

- Schnell und präzise auswuchten
- Keine Beschädigung des Futter
- Beliebig oft wiederholbar
- Einfache Fixierung mit Klemmschraube
- Passend für alle Fabrikate
- Die Auswuchtmaschine bestimmt die Position der Ringe (z. B. HAIMER Tool Dynamic)

- Lieferumfang: 2 Auswuchtringe mit Klemmschrauben ohne Innensechskantschlüssel

For fine-balancing of all tool holders with cylindrical outer diameter (diam. A).

The balancing index rings have a defined unbalance in themselves. They are turned in such a position that the unbalance of the tool holder will be compensated. There are always 2 rings needed per balancing plane.

- Balancing quickly and precisely
- No damage of tool holder
- Can be repeated as often as necessary
- Simply fixed by clamping screw
- Suitable for tool holders of all brands
- The balancing machine determines the position of the rings (e. g. HAIMER Tool Dynamic)

- Included in delivery: 2 balancing rings with clamping screws without hex wrench

	$\varnothing A$ [mm]	Unwucht ¹⁾ unbalance	Drehzahl rpm [1./min]
Bestell-Nr./Order No. 79.350.15	15	9 g·mm	max. 55.000
79.350.17	17	12 g·mm	max. 55.000
79.350.19	19	16 g·mm	max. 55.000
79.350.20	20	17 g·mm	max. 55.000
79.350.22	22	20 g·mm	max. 55.000
79.350.24	24	27 g·mm	max. 55.000
79.350.25	25	32 g·mm	max. 55.000
79.350.26	26	33 g·mm	max. 50.000
79.350.27	27	33 g·mm	max. 50.000
79.350.28	28	40 g·mm	max. 50.000
79.350.30	30	45 g·mm	max. 45.000
79.350.32	32	36 g·mm	max. 45.000
79.350.34	34	40 g·mm	max. 40.000
79.350.35	35	48 g·mm	max. 40.000
79.350.36	36	47 g·mm	max. 40.000
79.350.38	38	53 g·mm	max. 35.000
79.350.40	40	57 g·mm	max. 35.000
79.350.42	42	65 g·mm	max. 35.000
79.350.43	43	65 g·mm	max. 35.000
79.350.44	44	68 g·mm	max. 35.000
79.350.46	46	75 g·mm	max. 35.000
79.350.48	48	81 g·mm	max. 30.000
79.350.50	50	87 g·mm	max. 30.000
79.350.52	52	94 g·mm	max. 30.000
79.350.53	53	86 g·mm	max. 30.000
79.350.54	54	91 g·mm	max. 30.000
79.350.55	55	94 g·mm	max. 30.000

	$\varnothing A$ [mm]	Unwucht ¹⁾ unbalance	Drehzahl rpm [1./min]
Bestell-Nr./Order No. 79.350.56	56	100 g·mm	max. 30.000
79.350.58	58	106 g·mm	max. 30.000
79.350.60	60	110 g·mm	max. 25.000
79.350.62	62	120 g·mm	max. 25.000
79.350.63	63	123 g·mm	max. 25.000
79.350.64	64	126 g·mm	max. 25.000
79.350.65	65	129 g·mm	max. 25.000
79.350.66	66	120 g·mm	max. 25.000
79.350.68	68	135 g·mm	max. 25.000
79.350.70	70	145 g·mm	max. 25.000
79.350.72	72	152 g·mm	max. 25.000
79.350.74	74	160 g·mm	max. 25.000
79.350.76	76	168 g·mm	max. 20.000
79.350.78	78	178 g·mm	max. 20.000
79.350.80	80	186 g·mm	max. 20.000
79.350.82	82	199 g·mm	max. 20.000
79.350.84	84	215 g·mm	max. 20.000
79.350.86	86	224 g·mm	max. 20.000
79.350.87	87	225 g·mm	max. 20.000
79.350.88	88	226 g·mm	max. 20.000
79.350.89	89	231 g·mm	max. 20.000
79.350.90	90	237 g·mm	max. 20.000
79.350.92	92	247 g·mm	max. 20.000
79.350.94	94	253 g·mm	max. 20.000
79.350.96	96	267 g·mm	max. 20.000
79.350.98	98	277 g·mm	max. 20.000
79.350.100	100	285 g·mm	max. 15.000

1) Unwucht g·mm sind Richtwerte, geringe Abweichungen möglich
Unbalance g·mm are reference values, little variances possible

Technische Änderungen vorbehalten
Technical data subject to change without prior notice

WUCHTSCHRAUBENSATZ/SET OF BALANCING SCREWS



Zum Feinwuchten von Werkzeugaufnahmen mit Wuchtgewinden M 6 (z. B. Schrumpffutter von HAIMER).

Die Wuchtschrauben haben verschiedene Gewichte in einer feinen Abstufung. Sie werden in die vorhandenen Wuchtgewinde des Futters gedreht, so dass ihr Gewicht die Unwucht des Futters ausgleicht.

- Sortiment mit 11 verschiedenen Schraubengrößen mit verschiedenen Gewichten
- Die Schrauben werden bis auf den Grund des Gewindes gedreht und festgezogen. Keine Schraubensicherung notwendig.
- Schnell und präzise auswuchten
- Keine Beschädigung der Werkzeugaufnahme
- Beliebig oft wiederholbar
- Passend für alle Fabrikate
- Die Auswuchtmaschine berechnet das benötigte Gewicht (z. B. HAIMER TOOL DYNAMIC)
- Lieferumfang: Kassette mit 11 x 10 Wuchtschrauben, Schraubendreher

For fine-balancing of all tool holders with balancing threads M 6 (e. g. shrink fit chucks from HAIMER).

The screws have different weights in a fine graduation. They are screwed into the balancing threads of the tool holder so that their weight compensates the unbalance of the tool holder.

- Set consisting of screws of 11 different sizes and weights
- Screws are screwed to the ground of the thread and tightened. No additional fixing of screws necessary.
- Balancing quickly and precisely
- No damage of tool holders
- Can be repeated as often as necessary
- Suitable for tool holders of all brands
- The balancing machine calculates the necessary weight of the screws (e. g. HAIMER TOOL DYNAMIC)
- Included in delivery: Case with 11 x 10 balancing screws, screw driver

Wuchtschraubensatz/Set of balancing screws

Bestell-Nr./Order No. 80.203.00

SCHRUMPFUTTERBÜRSTE/SHRINK FIT BRUSH

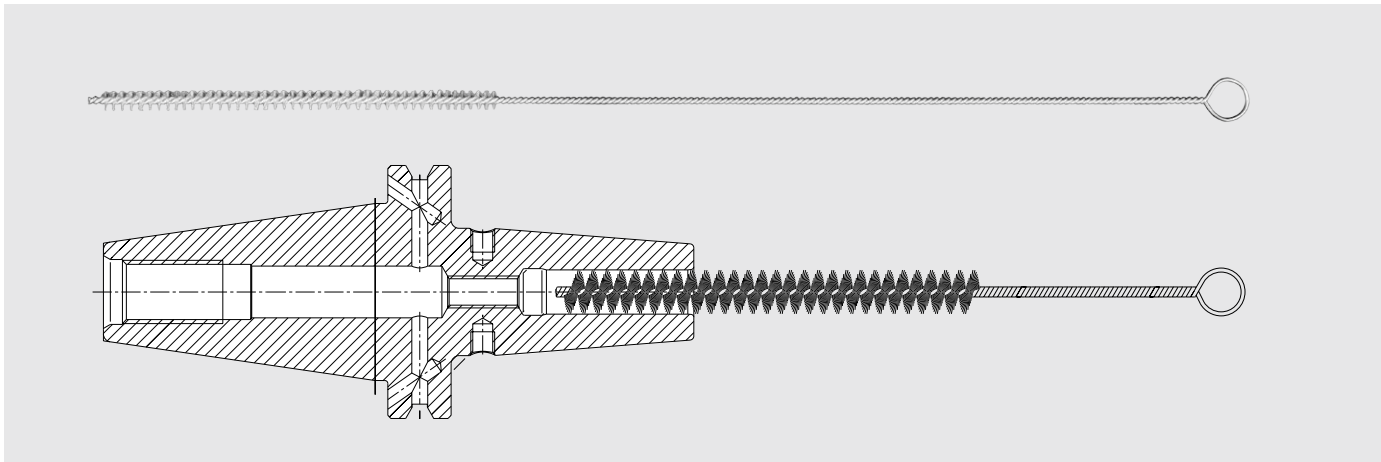

Um optimale Haltekräfte im Schrumpfsitz zu erzielen, muss die Schrumpfböhrung sauber und fettfrei sein. Die Reinigung sollte mit einem Lösungsmittel erfolgen, z. B. Bremsenreiniger. Mit der Schrumpffutterbürste kann die Schrumpfböhrung bis auf den Grund gereinigt werden.

In order to achieve the best possible shrink fit connection, a grease free socket and shank is necessary. The cleaning can be done by a cold solvent (e.g. brake cleaner). An appropriate cleaning brush is necessary to clean the socket of the Shrink Fit Chuck.

Schrumpffutterbürste/Shrink Fit Brush	Ø [mm]
Bestell-Nr./Order No. 86.200.01	3
86.200.02	3.5
86.200.02	4
86.200.02	4.5
86.200.02	5
86.200.03	6
86.200.03	8

Schrumpffutterbürste/Shrink Fit Brush	Ø [mm]
Bestell-Nr./Order No. 86.200.04	10
86.200.04	12
86.200.06	14
86.200.06	16
86.200.07	18
86.200.07	20
86.200.08	25

KÜHLMITTELROHR/COOLANT TUBE

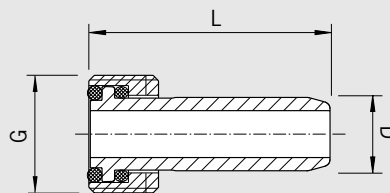

- Verhindert Verschmutzung der Spindel
- Notwendig für alle HSK-Maschinen mit Innenkühlung
- Zwei O-Ringe für leichte Beweglichkeit des Rohres
- Spezialbeschichtung mit extrem glatter Oberfläche
- Schont das Dichtsystem der Spindel
- Passend für alle Fabrikate

- Prevents spindle from being spoiled
- Must be used with all coolant through HSK spindles
- Dual o-ring design makes tube slightly movable
- Special coating with extremely smooth surface
- No damaging of the sealing system
- Fits all brands of HSK holders

Kühlmittelrohr/Coolant tube with 2 o-rings	HSK-A32	HSK-A40	HSK-A50	HSK-A63	HSK-A80	HSK-A100	HSK-A125
	HSK-E32	HSK-E40	HSK-E50				
Bestell-Nr./Order No. 85.700...	...32	...40	...50	...63	...80	...100	...125

Zubehör/Accessories

Schlüssel für/Wrench for
Bestell-Nr./Order No. 84.500...

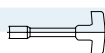

HSK-32	HSK-40	HSK-50	HSK-63	HSK-80	HSK-100	HSK-125
...32	...40	...50	...63	...80	...100	...125

KEGELWISCHER/CONE WIPER

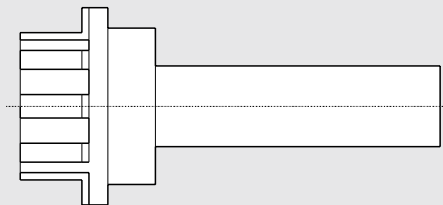

Kegelwischer/Cone wiper HSK	HSK-32	HSK-40	HSK-50	HSK-63	HSK-80	HSK-100
Bestell-Nr./Order No. 85.820...	...32	...40	...50	...63	...80	...10

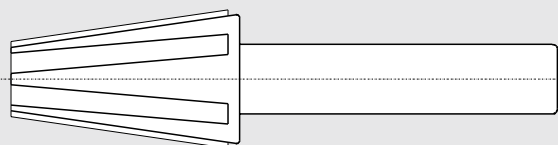

Kegelwischer/Cone wiper SK, BT, CAT	SK40	BT40	CAT40	SK50	BT50	CAT50
Bestell-Nr./Order No. 86.100...	...40	...40	...40	...50	...50	...50

Kegelwischer/Cone wiper MK	MK 01	MK 02	MK 03	MK 04
Bestell-Nr./Order No. 86.100...	...01	...02	...03	...04

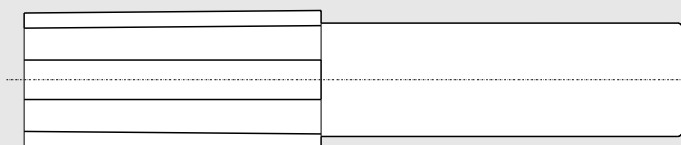

Kegelwischer/Cone wiper HG	HG 01	HG 02	HG 03
Bestell-Nr./Order No. 82.590...	...01	...02	...03

Zum Reinigen des Innenkegels von HG-Futtern/For cleaning the inner cone of HG chucks

EINSTELLSCHRAUBEN FÜR SCHRUMPFUTTER BACK UP SCREWS FOR SHRINK FIT CHUCKS

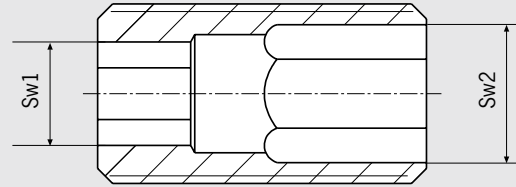
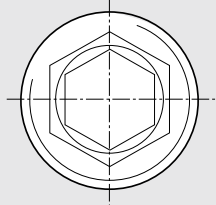

- Innensechskant an jedem Ende – immer zugänglich
- Seitlich abgeflacht für optimalen Kühlmittelabfluss
- Feingewinde für höchste Genauigkeit

- Hexagon socket on each end – can always be reached
- Flats on sides for optimized coolant drainage
- Fine thread for maximum accuracy

[mm]	Typ/Type	SK40/50 BT40/50	HSK-A32/E32 A40/E40	HSK-A50/ E50	HSK-A63	HSK-F63	HSK-A80	HSK-A100
Spann-Ø Clamping Ø	Länge/Length Bestell-Nr. Order No.							
6	85.810...	...12.1	...12.1	...12.1	...12.1	...12.1	...12.1	...12.1
8		...15.1	...15.1	...15.1	...15.1	...15.1	...15.1	...15.1
10	kurz/short andere/other	...18.2 ...18.2	...18.2 ...36.2	...18.2 ...36.2	...18.2 ...36.2	...18.2 ...36.2	...18.2 ...36.2	...18.2 ...36.2
12	kurz/short andere/other	...24.2 ...24.2	...24.2 ...24.2	...39.2 ...24.2	...39.2 ...24.2	...39.2 ...24.2	...21.2 ...24.2	...21.2 ...24.2
14	kurz/short ZG130/oversize	...24.2 ...24.2	...24.2 ...24.2	...39.2 ...24.2	...39.2 ...24.2	— —	...21.2 ...24.2	...21.2 ...24.2
16	kurz/short ZG130/oversize	...46.2 ...46.2	...27.2 ...27.2	...25.2 ...38.2	...25.2 ...46.2	...25.2 ...46.2	...27.2 ...46.2	...40.1 ...46.2
18	kurz/short ZG130/oversize	...46.2 ...46.2	— —	...25.2 ...38.2	...25.2 ...46.2	— —	...27.2 ...46.2	...40.1 ...46.2
20	kurz/short ZG130/oversize	...52.2 ...52.2	— —	...51.2 ...52.2	...51.2 ...52.2	...51.2 ...52.2	...51.2 ...52.2	...51.2 ...52.2
25	kurz/short ZG130/oversize	...52.2 ...52.2	— —	— —	...52.2 ...52.2	...52.2 ...52.2	...52.2 ...52.2	...52.2 ...52.2
32	kurz/short ZG130/oversize	...52.2 ...52.2	— —	— —	...52.2 ...52.2	— —	...52.2 ...52.2	...52.2 ...52.2

Bestell-Nr./Order No.	SW1	SW2	Gewinde/Thread
85.810.12.1	SW2,5	SW2,5	M5x0,8x16
85.810.15.1	SW3	SW3	M6x1x16
85.810.18.2	SW3	SW4	M8x1x16
85.810.24.2	SW4	SW5	M10x1x20
85.810.25.2	SW5	SW6	M12x1x18
85.810.27.2	SW4	SW6	M12x1x18
85.810.36.2	SW3	SW4	M8x1x20
85.810.46.2	SW6	SW6	M12x1x20

Bestell-Nr./Order No.	SW1	SW2	Gewinde/Thread
85.810.21.2	SW4	SW5	M10x1x16
85.810.38.2	SW5	SW6	M12x1x22
85.810.39.2	SW4	SW5	M10x1x18
85.810.40.1	SW6	SW6	M12x1x16
85.810.51.2	SW5	SW8	M16x1x18
85.810.52.2	SW6	SW8	M16x1x22

LANGE EINSTELLSCHRAUBEN FÜR SCHRUMPFUTTER BACK UP SCREWS LONG FOR SHRINK FIT CHUCKS

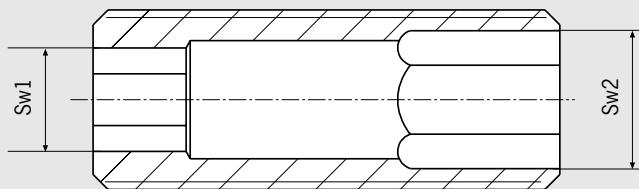
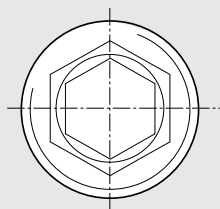

- Innensechskant an jedem Ende – immer zugänglich
- Seitlich abgeflacht für optimalen Kühlmittelabfluss
- Feingewinde für höchste Genauigkeit

- Hexagon socket on each end – can always be reached
- Flats on sides for optimized coolant drainage
- Fine thread for maximum accuracy

[mm]	Typ/Type	SK40/50 BT40/50	HSK-A32/E32 A40/E40	HSK-A50/ E50	HSK-A63	HSK-F63	HSK-A80	HSK-A100
Spann-Ø Clamping Ø	Länge/Length Bestell-Nr. Order No. 85.810...							
6		...12.4	...12.4	...12.4	...12.4	...12.4	...12.4	...12.4
8		...15.4	...15.4	...15.4	...15.4	...15.4	...15.4	...15.4
10		...18.4	...18.4	...18.4	...18.4	...18.4	...18.4	...18.4
12		...21.4	...21.4	...21.4	...21.4	...21.4	...21.4	...21.4
14		...21.4	...21.4	...21.4	...21.4	...21.4	...21.4	...21.4
16	kurz/short ZG130/oversize	...37.4 ...37.4	...27.4 ...27.4	...25.4 ...25.4	...25.4 ...37.4	...25.4 ...37.4	...27.4 ...37.4	...40.4 ...37.4
18	kurz/short ZG130/oversize	...37.4 ...37.4	— —	...25.4 ...25.4	...25.4 ...37.4	...25.4 ...37.4	...27.4 ...37.4	...40.4 ...37.4
20	kurz/short ZG130/oversize	...52.4 ...52.4	— —	...52.4 ...52.4	...52.4 ...52.4	...52.4 ...52.4	...52.4 ...52.4	...52.4 ...52.4
25		...52.4	—	—	...52.4	...52.4	...52.4	...52.4
32		...52.4	—	—	...52.4	...52.4	...52.4	...52.4

Bestell-Nr./Order No.	SW1	SW2	Gewinde/Thread
85.810.12.4	SW2,5	SW2,5	M5x0,8x24
85.810.15.4	SW3	SW3	M6x1x24
85.810.18.4	SW3	SW4	M8x1x24
85.810.21.4	SW4	SW5	M10x1x28
85.810.25.4	SW5	SW6	M12x1x34
85.810.27.4	SW4	SW6	M12x1x34
85.810.37.4	SW6	SW8	M12x1x34
85.810.52.4	SW6	SW8	M16x1x34

1) HSK-A 32 Ø 12 = Bestell-Nr./Order No. 85.810.18.4
2) Pos. in () für alten Standard/Pos. in () for old Standard

Technische Änderungen vorbehalten
Technical data subject to change without prior notice

EINSTELLSCHRAUBEN FÜR WHISTLE-NOTCH BACK UP SCREWS FOR WHISTLE NOTCH

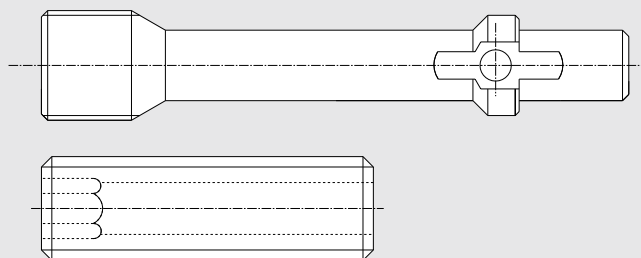

Größe/Size Ø D1 [mm]		DIN 69871, SK40	DIN 69871, SK50	JIS B 6339, BT40	JIS B 6339, BT50	DIN 69893, HSK-A63, HSK-A80, HSK-A100
6	kurz/short	85.150.01	85.150.03	85.150.01	85.150.03	85.810.02
6	lang/long	85.150.04	85.150.04	85.150.04	85.150.04	85.810.12.1
6	ZG 130	85.150.05	85.150.05	—	—	—
6	überlang/oversize	85.150.07	85.150.07	85.150.07	85.150.07	85.810.02
8	kurz/short	85.150.01	85.150.03	85.150.01	85.150.03	85.810.05
8	lang/long	85.150.04	85.150.04	85.150.04	85.150.04	85.810.15.1
8	ZG 130	85.150.05	85.150.05	—	—	—
8	überlang/oversize	85.150.07	85.150.07	85.150.07	85.150.07	85.810.05
10	kurz/short	85.150.01	85.150.03	85.150.02	85.150.03	85.810.09
10	lang/long	85.150.04	85.150.04	85.150.04	85.150.04	85.810.18.2
10	ZG 130	85.150.05	85.150.05	—	—	—
10	überlang/oversize	85.150.07	85.150.07	85.150.07	85.150.07	85.810.36.2
12	kurz/short	85.150.01	85.150.01	85.150.01	85.150.02	85.810.14
12	lang/long	85.150.04	85.150.04	85.150.04	85.150.04	85.810.24.2
12	ZG 130	85.150.05	85.150.05	—	—	—
12	überlang/oversize	85.150.06	85.150.07	85.150.06	85.150.07	85.810.14
14	kurz/short	85.150.01	85.150.01	85.150.01	85.150.02	85.810.14
14	lang/long	85.150.04	85.150.04	85.150.04	85.150.04	85.810.24.2
14	ZG 130	85.150.05	85.150.05	—	—	—
14	überlang/oversize	85.150.06	85.150.06	85.150.06	85.150.07	85.810.14
16	kurz/short	85.150.01	85.150.01	85.150.01	85.150.02	85.810.18
16	lang/long	85.150.04	85.150.04	85.150.04	85.150.04	85.810.46.2
16	ZG 130	85.150.05	85.150.05	—	—	—
16	überlang/oversize	85.150.07	85.150.06	85.150.06	85.150.06	85.810.18
18	kurz/short	85.150.01	85.150.01	85.150.01	85.150.02	85.810.18
18	lang/long	85.150.04	85.150.04	85.150.04	85.150.04	85.810.46.2
18	ZG 130	85.150.05	85.150.05	—	—	—
18	überlang/oversize	85.150.07	85.150.06	85.150.06	85.150.06	85.810.18
20	kurz/short	85.150.01	85.150.01	85.150.01	85.150.02	85.810.27
20	lang/long	85.150.04	85.150.04	85.150.04	85.150.04	85.810.38.2
20	ZG 130	85.150.05	85.150.05	—	—	—
20	überlang/oversize	85.150.07	85.150.06	85.150.06	85.150.06	85.810.27
25	kurz/short	85.150.03	85.150.02	85.150.03	85.150.03	85.810.27
25	lang/long	—	—	—	—	85.810.38.2
25	ZG 130	85.150.08	85.150.08	—	—	—
25	überlang/oversize	85.150.06	85.150.06	85.150.06	85.150.06	85.810.27
32	kurz/short	—	85.150.03	85.150.03	85.150.03	85.810.27
32	lang/long	—	—	—	—	85.810.38.2
32	ZG 130	—	85.150.08	—	—	—
32	überlang/oversize	—	85.150.06	85.150.06	85.150.06	85.810.27
40	kurz/short	—	85.150.02	—	85.150.03	—
40	lang/long	—	—	—	—	—
40	ZG 130	—	85.150.08	—	—	—
40	überlang/oversize	—	85.150.05	—	85.150.05	—

LÄNGENEINSTELLSCHRAUBEN FÜR SPANNZANGENFUTTER ER BACK UP SCREWS FOR COLLET CHUCKS

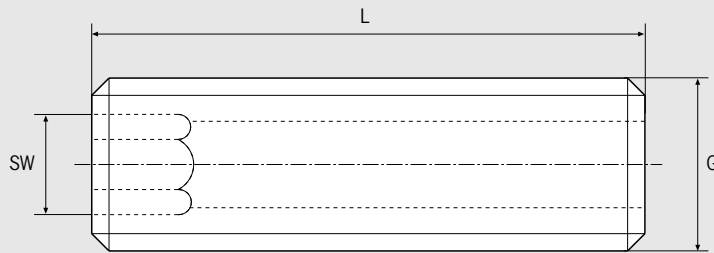

Größe/Size Ø [mm]	HSK-32, 40, 50, 63, 80, 100	SW	L [mm]	Gewinde/Thread
ER 16	Bestell-Nr./Order No. 85.800.34	3	25	M6
ER 20	85.800.34	3	25	M6
ER 25	85.800.34	3	25	M6
ER 32	85.800.35	5	25	M10
ER 40	85.800.35	5	25	M10

VORSPANNFEDERN FÜR SCHRUMPFUTTER TENSION SPRINGS FOR SHRINK FIT CHUCKS

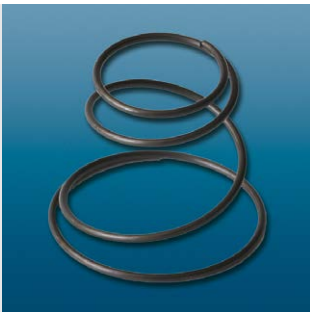

- Feder wird in die Spannbohrung eingesetzt
- Feder drückt das Werkzeug gegen den Anschlag
- Passt in alle gängigen Schrumpffutter
- Einstellschraube kann im Futter bleiben

- Spring is set into clamping bore
- Spring presses tool against stop disc
- Fits all common shrink fit chucks
- Backup screw can remain in chuck

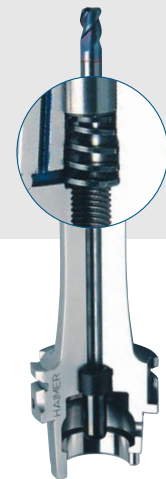

Vorspannfeder für Längeneinstellung
Tension spring for length presetting

Vorspannfeder/Tension spring	Ø 6	Ø 8	Ø 10	Ø 12	Ø 14	Ø 16	Ø 18	Ø 20	Ø 25	Ø 32	Bestell-Nr./Order No.
Bestell-Nr./Order No. 85.830...	...06	...08	...10	...12	...14	...16	...18	...20	...25	...32	
Vorspannfeder Set bestehend aus 10 Stk. je Größe inkl. Ausziegreifer/Tension spring set (10 pcs. of each size) incl. grab											85.830.00

SPANNSCHRAUBEN FÜR WELDON- UND WHISTLE-NOTCH AUFNAHMEN CLAMPING SCREWS FOR WELDON AND WHISTLE NOTCH

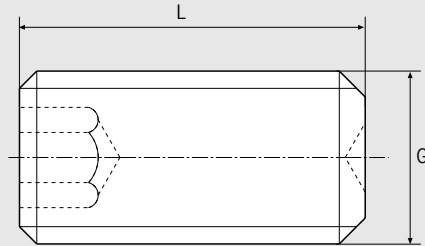

Spann/Clamping	Ø D1 [mm]	06	08	10	12	14	16	18	20	25	25	32	40
Bestell-Nr./Order No. 85.100...		...06	...08	...10	...12	...12	...14	...14	...16	...18	ultrakurz ultra short	...20	...20
G		M6	M8	M10	M12	M12	M14	M14	M16	M18x2	M18x2	M20x2	M20x2
L		10	10	12	16	16	16	16	16	20	13	20	20

SPANNSCHRAUBEN FÜR HG-FUTTER CLAMPING SCREWS FOR HG CHUCK

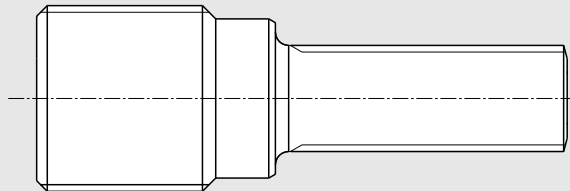

		DIN 69871 SK 40	DIN 69871 SK 50	MAS BT 40	MAS BT 50	HSK-A63	HSK-F63	HSK-A80	HSK-A100
für Maß/for length	kurz/short	40.420.01	50.420.01	40.620.01	—	A 63.120.01	F 63.120.01	A 80.120.01	A 10.120.01
Bestell-Nr./Order No. 82.560...		...03	...03	...03		...02	...02	...02	...02
für Maß/for length	kurz/short	40.420.02	50.420.02	40.620.02	—	A 63.120.02	F 63.120.02	A 80.120.02	A 10.120.02
Bestell-Nr./Order No. 82.560...		...02	...02	...02		...14	...14	...14	...14
für Maß/for length	kurz/short	40.420.03	50.420.03	40.620.03	—	A 63.120.03	F 63.120.03	A 80.120.03	A 10.120.03
Bestell-Nr./Order No. 82.560...		...02	...02	...02		...14	...14	...14	...14
für Maß/for length	lang/long	40.421.01	50.421.01	40.621.01	50.621.01	—	—	—	—
Bestell-Nr./Order No. 82.560...		...04	...04	...04	...04				
für Maß/for length	lang/long	40.421.02	50.421.02	40.621.02	50.621.02	—	—	—	—
Bestell-Nr./Order No. 82.560...		...01	...01	...01	...01				
für Maß/for length	lang/long	40.421.03	50.421.03	40.621.03	50.621.03	—	—	—	—
Bestell-Nr./Order No. 82.560...		...05	...05	...05	...17				
für Maß/for length	überlang/extralong	40.422.01	50.422.01	40.622.01	50.622.01	A 63.122.01	—	A 80.122.01	A 10.122.01
Bestell-Nr./Order No. 82.560...		...08	...08	...08	...08	...04		...04	...04
für Maß/for length	überlang/extralong	40.422.02	50.422.02	40.622.02	50.622.02	A 63.122.02	—	A 80.122.02	A 10.122.02
Bestell-Nr./Order No. 82.560...		...06	...06	...06	...06	...01		...05	...05
für Maß/for length	überlang/extralong	40.422.03	50.422.03	40.622.03	50.622.03	A 63.122.03	—	A 80.122.03	A 10.122.03
Bestell-Nr./Order No. 82.560...		...07	...07	...07	...07	...01		...05	...05

MESSERKOPF-, KOMBI-ZUBEHÖR
ACCESSORIES FACE MILL AND COMBINATION ARBORS

MITNEHMERRINGE/DRIVING RINGS

Aufnahme-Ø/Tool holder Ø	16	22	27	32	40	50
Ø D [mm]	32	40	48	58	70	90
L [mm]	10	12	12	14	14	16
Bestell-Nr./Order No. 85.200...	...16	...22	...27	...32	...40	...50

Mitnehmerringe für DIN 6366/1 für Kombiaufsteckfräserdorne

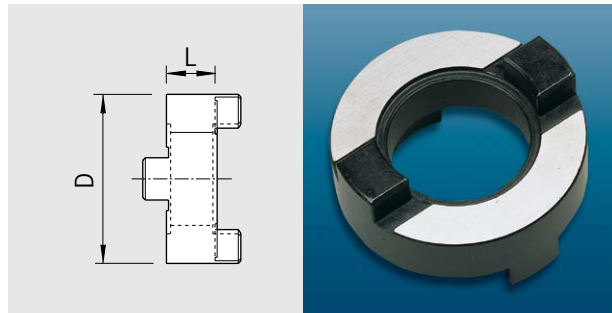

Driving rings DIN 6366/1 for combination shell end mill adapters

FRÄSERANZUGSSCHRAUBEN
TIGHTENING BOLTS

Aufnahme-Ø/Tool holder Ø	16	22	27	32	40	50	60
Ø D [mm]	20	28	35	42	52	63	75
L [mm]	22	25	30	35	40	48	59
G	M8	M10	M12	M16	M20	M24	M30
Bestell-Nr./Order No. 85.300...	...16	...22	...27	...32	...40	...50	...60

Fräseranzugsschrauben DIN 6367 für Kombiaufsteckfräserdorne und Messerkopfaufnahmen

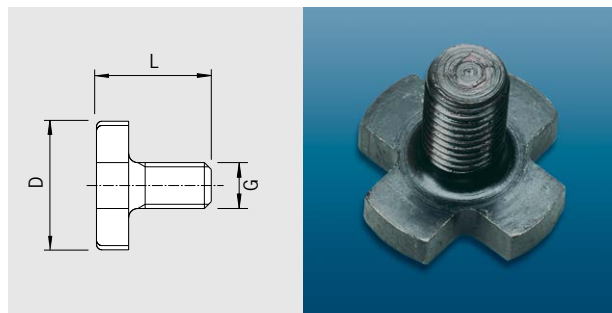

Tightening bolts DIN 6367 for combination shell end mill adapters and face mill arbors

PASSFEDERN/FEATHER KEYS

Aufnahme-Ø/Tool holder Ø	16	22	27	32	40	50
L [mm]	20	25	25	28	32	36
B [mm]	4	6	7	8	10	12
Bestell-Nr./Order No. 85.400...	...16	...22	...27	...32	...40	...50

Passfedern DIN 6885 mit Abdrückschraube für Kombiaufsteckfräserdorne

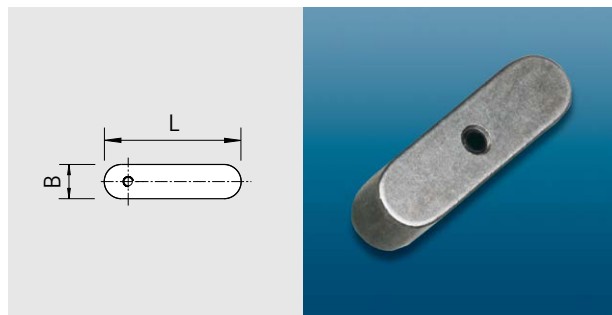

Feather keys DIN 6885 with loosening screw for combination shell end mill adapters

UMRÜSTSATZ AD-B
CONVERSION KIT AD-B

Größe/Size	SK40	SK50
Bestell-Nr./Order No. 85.600...	...40	...50

Umrüstsatz Form AD/Form B je 50 Dichtdübel und Spanschrauben

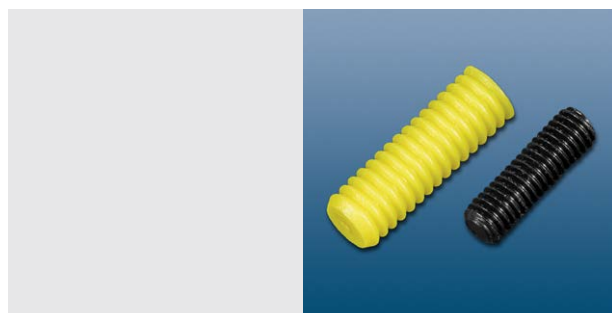

Conversion kit form AD/form B comprising each 50 sealing dowels and lock screws

SCHNELLWECHSELEINSÄTZE TYP FH
QUICK CHANGE INSERTS TYPE FH

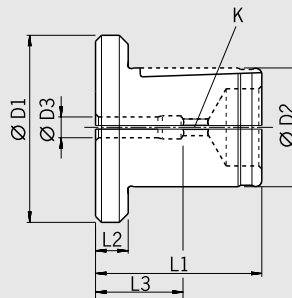

Nicht kompatibel mit Fa. Bilz/Not useable with comp. Bilz

Typ FH/Type FH				01	03			
Ø D1 [mm]				32	42			
Ø D2 [mm]				20	28			
L1 [mm]				28	35			
L2 [mm]				5,5	5,5			
Schneidbereich/Cutting range				M3-M14	M4,5-M24			
Schaft/Shank Ø D3	Vierkant K Square K	DIN 371	DIN 374/376 ISO	Schaftmaß Shank size	L3	Bestell-Nr. Order No.	L3	Bestell-Nr. Order No.
2,5	2,1	M1-M1,8	M3,5	—	11,5	80.501.02.5	—	—
2,8	2,1	M2-M2,5	M4	—	12	80.501.02.8	—	—
3,15	2,5	M3	M4,5-M5	M4-M3	13	80.501.03.1	—	—
3,5	2,7	M3	M4,5-M5	—	14,5	80.501.03.5	—	—
3,55	2,8	M3	M4,5-M5	M4,5-M3,5	14	80.501.03.6	—	—
4	3	M3,5	—	—	16	80.501.04.0	—	—
4	3,15	M3,5	—	M4-M5	16	80.501.04.3	—	—
4,5	3,4	M4	M6	—	17	80.501.04.5	—	—
5	4	M4	M6	M5	17	80.501.05.0	—	—
6	4,9	M4,5-M6	M8	—	17	80.501.06.0	17	80.503.06.0
6,3	5	M4,5-M6	M8	M6-M8	17	80.501.06.3	17	80.503.06.3
7	5,55	M7	M10	—	17	80.501.07.0	17	80.503.07.0
8	6,3	M8	—	—	17	80.501.08.0	20	80.503.08.0
9	7,1	—	M12	—	17	80.501.09.0	21	80.503.09.0
10	8	M10	—	—	17	80.501.10.0	21	80.503.10.0
11	9	—	M14	—	17	80.501.11.0	21	80.503.11.0
11,2	9	—	—	—	—	—	21	80.503.11.2
12	9	—	M16	—	—	—	21	80.503.12.0
12,5	10	—	M16	M16	—	—	21	80.503.12.5
14	11	—	M18	—	—	—	22	80.503.14.0
14	11,2	—	M18	M18-M20	—	—	22	80.503.14.2
16	12	—	M20	—	—	—	22	80.503.16.0
16	12,5	—	M20	M22	—	—	22	80.503.16.5
18	14,5	—	M22-M24	—	—	—	22	80.503.18.0

UMRÜSTSATZ DIN 2080-DIN 69871 CONVERSION KIT DIN 2080-DIN 69871

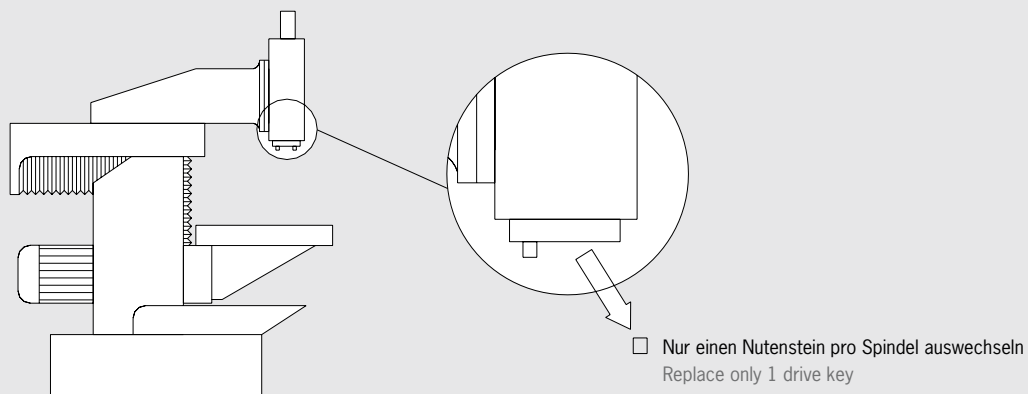

Sägewinde-Anzugsbolzen
Pullstud with saw thread

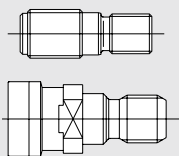

Ringnut-Anzugsbolzen
Pullstud with Ott-groove

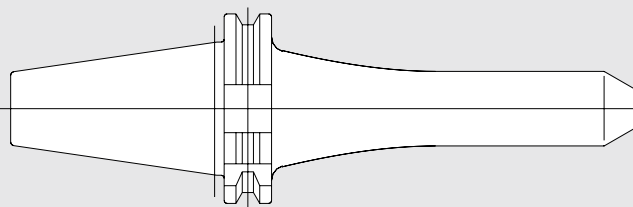
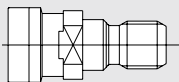

Beliebige DIN 69871 Werkzeugaufnahme
Tool holder DIN 69871

Zum Umrüsten von Spindeln DIN 2080 für Werkzeugaufnahmen DIN 69871/For conversion of spindles DIN 2080 for tool holders DIN 69871



2 Austauschnutensteine mit Befestigungsschrauben
2 drive keys with clamping screws
SK 40: Bestell-Nr./Order No. 85.500.40
SK 50: Bestell-Nr./Order No. 85.500.50

HAIMER[®]
Quality Wins.



Werkzeugtechnik
Tooling Technology



Schrumpftechnik
Shrinking Technology



Auswuchttechnik
Balancing Technology



Messgeräte
Measuring Instruments



Tool Management



Haimer GmbH | Weiherstrasse 21 | 86568 Igenhausen | Germany

Telefon/Phone +49-8257-9988-0 | Fax +49-8257-1850 | E-Mail: haimer@haimer.de | www.haimer.com

5.0 M&S · 3. Auflage 02/15 · Gedruckt in Deutschland · Gedruckt auf 100% chlorfrei gebleichtem Papier · D180215 DE/GB · Technische Änderungen vorbehalten.